

FMS Telemetry Systems / Extensions

RTM X42.CC Control Center System Extension with Master Controller and FMS Monitoring & Control Software

- **Monitor your Process Data:**
Display measurement values and other relevant parameters
- **Seamless Quality Documentation:**
Generate quality reports for in-house or customer knowledge base
- **All Process Data under Control:**
Documentation of process data, recipe manager to create, store and retrieve pre-defined production settings
- **Ease of Use:**
Graphical user interface, recipe manager and quality report manager can be operated from remote work stations with network connection

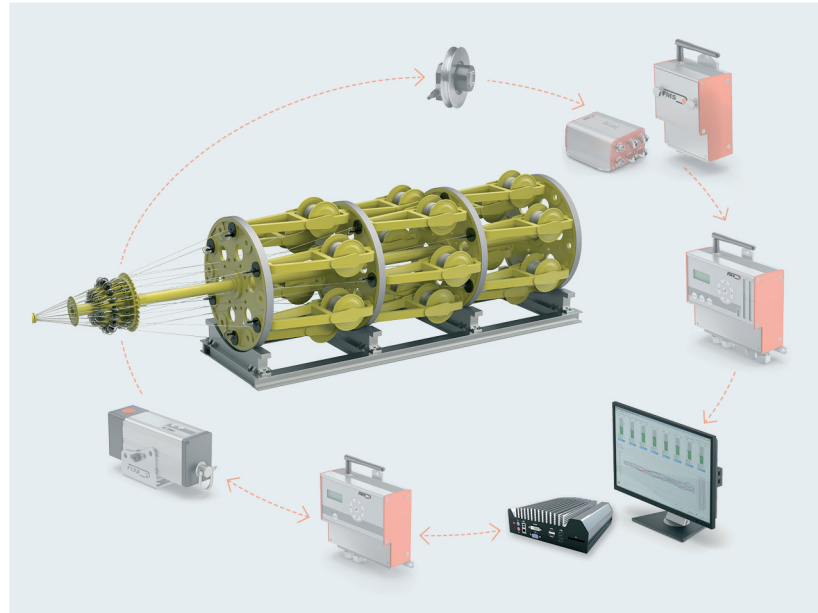

RTM X42.CC Control Center

The RTM X42.CC Control Center is an extension to the RTM X42 Telemetry System. This extension provides easy to use tools related to the management of wire tension measurement and control. The visualization of the measured data is an important function of the system, and is in addition to the setup & commissioning parameters, the Recipe Manager and the Quality Report Manager where the generation of reports becomes a simple operation.

The RTM Monitoring & Control Software displays all relevant measuring and control (only with RTM X42.BC Brake Control) parameters at a glance. The Recipe Manager enables you to create, edit and store relevant settings of the RTM X42 System for a particular product run, and then retrieve them later for an identical product run. With this feature the machine setup procedure is simplified and as the process parameters are repeated the product quality will also follow. With a network connection the program can be run on any browser, independent from the RTM X42 main computer.

Functional Description

The RTM X42.CC Control Center consists of a master controller and the RTM Monitoring & Control Software. The software package is an FMS development based on decades of experience. It is preinstalled and offers functionality as follows:

- System configuration of the RTM X42 System
- Clear visualization of measured data
- Accurate documentation / recording of process and quality parameters
- Quality Report Manager
- Recipe Manager
- Control panel for closed-loop tension control (only in combination with RTM X42.BC Brake Control)

The single components of the RTM X42 System communicate via TCP Modbus protocol, and with the included browser it will run on any network PC.

The RTM X42.CC Control Center is a required extension to run and operate the RTM X42.BC Brake Control.

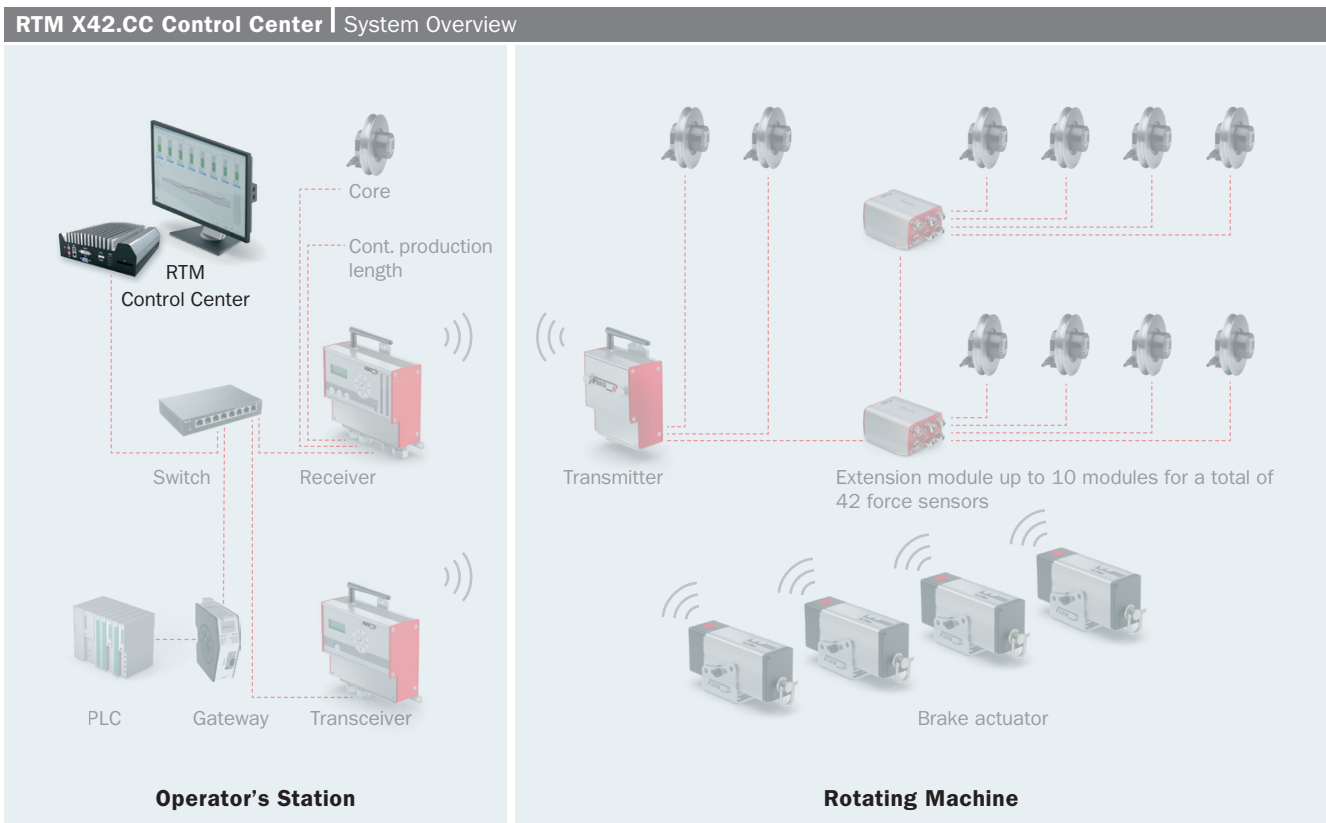

RTM X42.CC.PC Master Controller

Fanless, embedded

RTM X42.CC.SW Monitoring & Control Software

FMS independent development, browser based

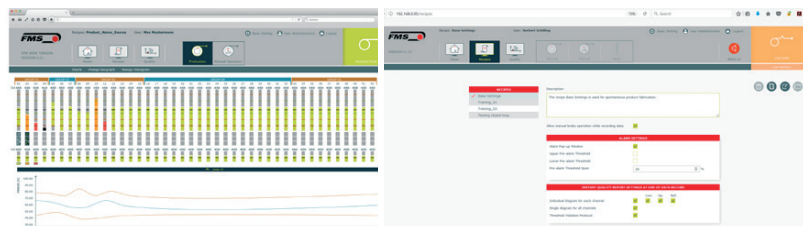

- Robust housing, protected against dirt
- Operating system Linux
- including monitor, keyboard and mouse

- Easy system configuration
- Visualisation of measuring data and control parameters
- Intuitive operation with graphical user interface
- Recipe Manager for various products and product variations
- Quality Manager for the generation and management of quality relevant documentation for you and your customers

RTM X42.CC Control Center Accessories	
BUS components	Anybus gateway, switch, cables, etc.
Installation and start-up	Our specialist can support you on-site if required

RTM X42.CC.PC Main Controller | Technical Data

Operating system	LINUX
RAM	1 x 204-pin SO-DIMM slot, up to 4 GB DDR3 1066 MHz SDRAM
Processor	Intel® Core*** i7-620M (2.66GHz)
I/O Interface	Ethernet, to 5 x Intel® 82574L GbE ports
Temperature range	-25 °C to 50 °C

RTM X42 System | Certification

ETSI Radio Certification

Magnitude of Test (Coverage)	Article 3.2 of Directive 1999/5/EC (R&TTE Directive)
Certification	ETSI EN 300 440-2 V1.5.1 (2009-03); ETSI EN 300 440-1 V1.3.1 (2009-03)

FCC Certification USA, Canada

Magnitude of Test (Coverage)	Class A digital device, pursuant to Part 15 of the FCC Rules
Certification	FCC Registration #: 0020311882

CAB Radio Certification for Japan

Magnitude of Test (Coverage)	Low power data communi. FXD; Art. 38-24, Paragraph 1 of radio law
Certification	Article 2, Clause 1 Item 19, Certification ID #: 202WWSM10126721

Lloyd's Register

Magnitude of Test (Coverage)	Appraisal Document No. HTS/ETS 37656-18 Certification
Certification	Lloyd's Register Type Approval Certificate No. 18/20083



RTM X42.CC.PC Master Controller | Dimensions in mm or [in]

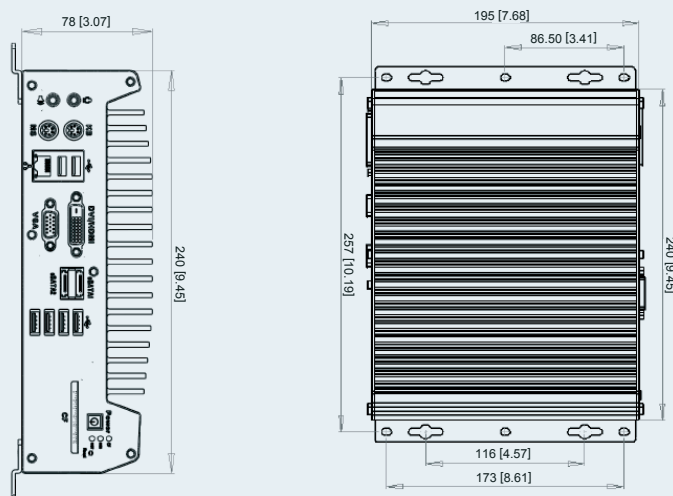

Telemetry Systems | Basic System Extensions and Accessories

RTM X42

Monitoring of strand tension and radio transmission of signals

RTM X42.BC Brake Control

Closed-loop control of pay-off brakes

BUS Components

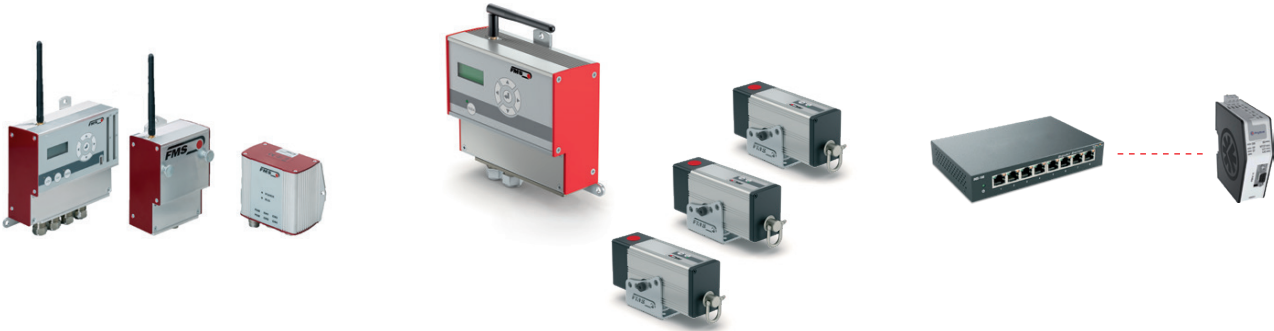

The range of accessories for the RTM X42 Telemetry Systems is characterized by its modularity. The basic system for tension measurement of wires or strands can be extended gradually. The RTM X42.CC Control Center offers tools for best quality documentation and process safety. A fully equipped RTM X42 system will additionally include the RTM X42.BC Brake Control which provides continuous, automatic wire tension control.

Other FMS Products for the Wire & Cable Industry

FMS offers a wide range of measuring sensors that can all be used in combination with our telemetry systems. A huge variety of nominal sizes (3 to 8000 N) and designs offers solutions for almost any application. FMS measuring amplifiers and tension controllers are applicable when wireless data transmission is not required or when wiring of the components is not an issue. Rely on us and our proven technology in this field. Contact us directly to get more information about our portfolio of analog and digital devices as well as our bus capabilities.

Telemetry Systems | Zubehör

RMGZ 200
Measuring Rollers

RMGZ 300
Measuring Rollers

EMGZ
Measuring Amplifiers

CMGZ
Tension Controllers

