

RTM X42.BC Brake Control Installation Instructions and User Manual

System Extension for Telemetry System RTM X42

Document Version 2.14
Published / author 05/2023 / NS

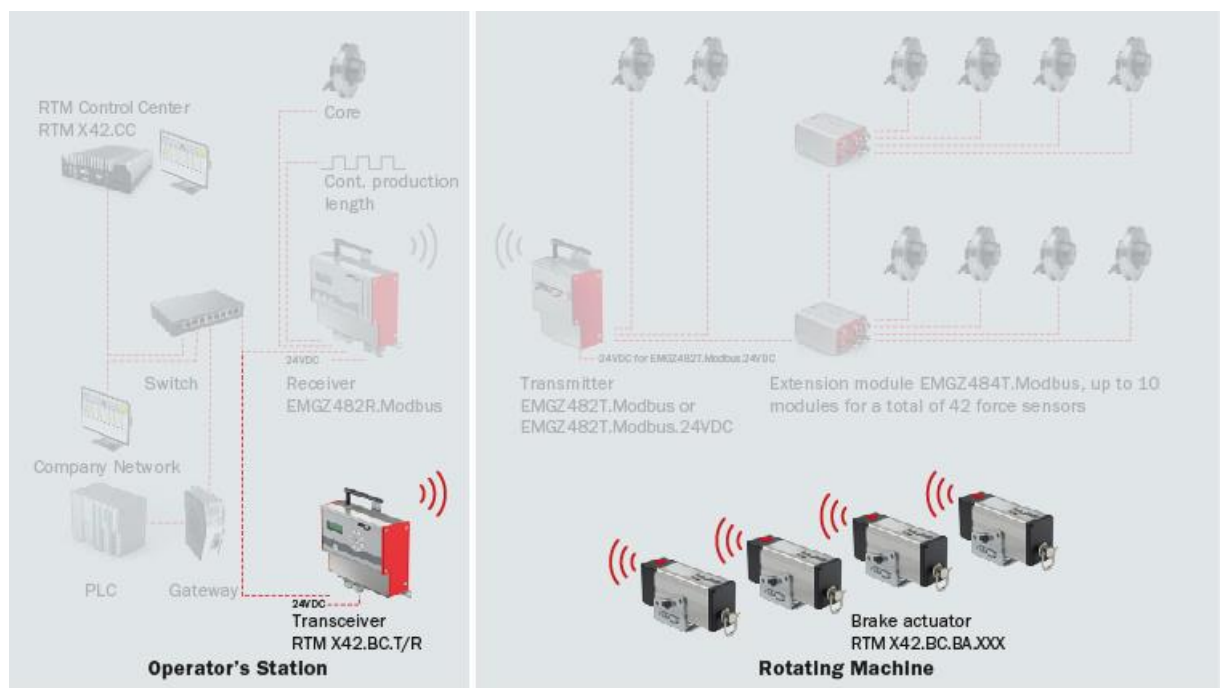

**Diese Bedienungsanleitung ist auch in Deutsch erhältlich.
Bitte kontaktieren Sie Ihren nächstgelegenen FMS Vertreter.**

1 Contents

1	CONTENTS	2
2	SAFETY INFORMATION	3
2.1	Presentation of Safety Information.....	3
2.1.1	Danger that Could Result in Minor or Moderate Injuries	3
2.1.2	Note Regarding Proper Function	3
2.2	General Safety Information	3
3	PRODUCT INFORMATION.....	5
3.1	System Requirements.....	5
3.2	Mode of Operation	5
3.3	Main Components	5
3.4	Scope of Delivery	6
4	INSTALLATION AND ELECTRICAL CONNECTION	7
4.1	RTM.X42.BC.T/R Transceiver	7
4.2	Electrical Connections of the RTM.X42.BC.T/R Transceiver	8
4.3	Specifications for sensors and switches	8
4.4	Configuration of relay outputs for sensors and switches	12
4.5	Installation of RTM X42.BC.BA.XXX Brake Actuator.....	19
4.5.1	Sizing of spring, spring package.....	21
5	MANUAL OPERATION OF THE BRAKE ACTUATORS.....	23
6	MAINTENANCE	24
7	DIMENSIONS	25
8	TECHNICAL DATA	28
8.1	RTM X42.BC.T/R Transceiver	28
8.2	RTMX42.BC.BA.600 Brake Actuator	28
8.3	RTMX42.BA.2500 Brake Actuator	29
8.4	24VDC Adapter for brake actuator RTM X42.BC.BA.24VDC	29
8.5	Radio Certification ETSI.....	30
8.6	Lloyd's Register Type Approval	30

2 Safety Information

All safety information, operating and installation regulations listed here ensure proper function of the device. Safe operation of the system requires compliance at all times. Noncompliance with the safety information or using the device outside of the specified performance data can endanger the safety and health of persons.

Work with respect to operation, maintenance, retrofit, repair, or setting the device described here must only be performed by expert personnel.

2.1 Presentation of Safety Information

2.1.1 Danger that Could Result in Minor or Moderate Injuries



Danger, warning, caution

Type of danger and its source

Possible consequences of nonobservance

Measure for danger prevention

2.1.2 Note Regarding Proper Function



Note

Note regarding proper operation

Simplification of operation

Ensuring function

2.2 General Safety Information



Flying parts

If the battery is not secured correctly, it can be ejected in the case of rotating machines.

Secure the battery using the knurled screws



Changes or modification to this device that have not been expressly approved by FMS AG, will result in the FCC approval for operation of this device being voided.



This device complies with the FCC Rules Part 15 as well as the RSS standards issued in Canada not requiring approval. Operation is

subject to the following two conditions:

- The device may not cause any harmful interference, and
- This device must accept any interference received, including interference that may cause undesired operation of the device

Information about radio frequency radiation



This device complies with the FCC limit values for an uncontrolled environment. This device should be installed and operated such that a minimum distance of 20 cm is maintained between radiation source and your body. This transmitter must not be operated near or in connection with another antenna or transmitter



The function of this system is only ensured with the components in the specified layout to one another. Otherwise, severe malfunctions may occur. Thus, the installation information on the following pages must be followed.



The local installation regulations ensure the safety of electrical systems. They are not considered in these operating instructions. However, they must be met.



Poor grounding can result in electric shocks for persons, malfunctions of the overall system or damage to the control electronics! Proper grounding must always be ensured.



It is of utmost importance to compensate for the centrifugal forces generated through the rotation of the strander. Non-compensated force-measuring rollers lead to faulty measurements.



Electrical connections must be implemented by an expert.



All system components are sensitive components that can be damaged in the case of improper installation! Installation must be performed by trained service personnel!

3 Product information

3.1 System Requirements

To be able to use the functionality of the RTM X42.BC Brake Control, an RTM X42.Modbus Telemetry System and the RTM X42.CC Control Center have to be installed.

3.2 Mode of Operation

The RTM X42.BC Brake Control is used for controlling the pay-off brakes of the bobbins in rotating stranding machines. One brake actuator each controls the brake resistance of a belt/rope brake on a cradle. The brake actuators operate completely independently. Each is driven via a rechargeable, replaceable battery pack.

The brake actuators receive the commands regarding changes of the brake tension via radio communication from the transceiver module that receives the actuating values via network connection from the RTM X42.CC Control Center.

RTM X42.BC Brake Control – System extension for continuous tension control

- Integrated solution, fully automated control of the pay-off brakes
- For belt and rope type friction brakes
- Continuous production with highest quality
- Simple concept, maintenance-free, robust
- Easy to retrofit, highest reliability
- Proven battery technology, ease of operation, long lifetime, highest efficiency

3.3 Main Components

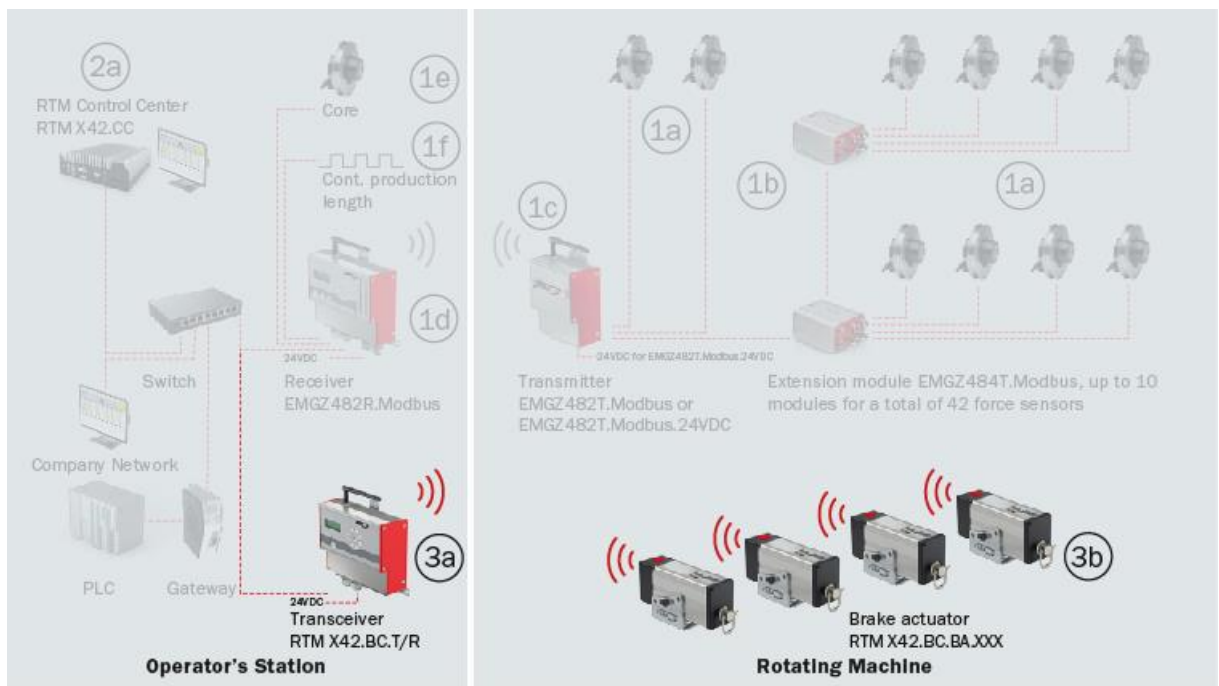

Figure 1: Main components RTMX42.BC

RTM_X42_Modbus_BA_Manual.ai

Main Components	
Item	Components
Pos. 3	System Extension RTM X42.BC Brake Control
3a	Transceiver module RTM X42.BC.T/R
3b	Brake actuator, illustrated RTM X42.BC.BA.600, incl. battery
not shown	Charger for battery

Table 1: Main components

3.4 Scope of Delivery

Included in the scope of delivery:

Transceiver module RTM X42.BC.T/R; brake actuator RTM X42.BC.BA.XXX with XXXN of max. brake force, battery, clevis and bracket; charger for battery

Not included in the scope of delivery:

24 VDC power supply for the RTM X42.BC.T/R transceiver; cable for power supply; installation material for transceiver and brake actuator

Accessories:

Patch cable from RTM X42.CC Control Center to RTM X42.BC.T/R Transceiver; right-angle connector, M16x1.5, 6-pole for digital inputs on brake actuator

4 Installation and Electrical Connection

4.1 RTM.X42.BC.T/R Transceiver

The transmission path to the brake actuators can be impaired by objects, such as racks, protection equipment, etc. When selecting the attachment location, ensure an interference-free connection between the RTM X42.BC.T/R transceiver and the individual brake actuators if possible.

Under ideal conditions, including line of sight and no obstructions between the transceivers, the maximum range is 20m (65ft). It is likely that in a production environment the range will be limited and obstruction factors such as machine covers, safety fencing, walls, etc. must be accounted for.

Attach the housing to any flat surface. Make sure that the housing is not subjected to any mechanical tension after assembly.



Abbildung 1: Installation

RTM_X42_BC_BA_Manual.ai

4.2 Electrical Connections of the RTM.X42.BC.T/R Transceiver

First, loosen the 4 screws of the cover to gain access to the terminal blocks.

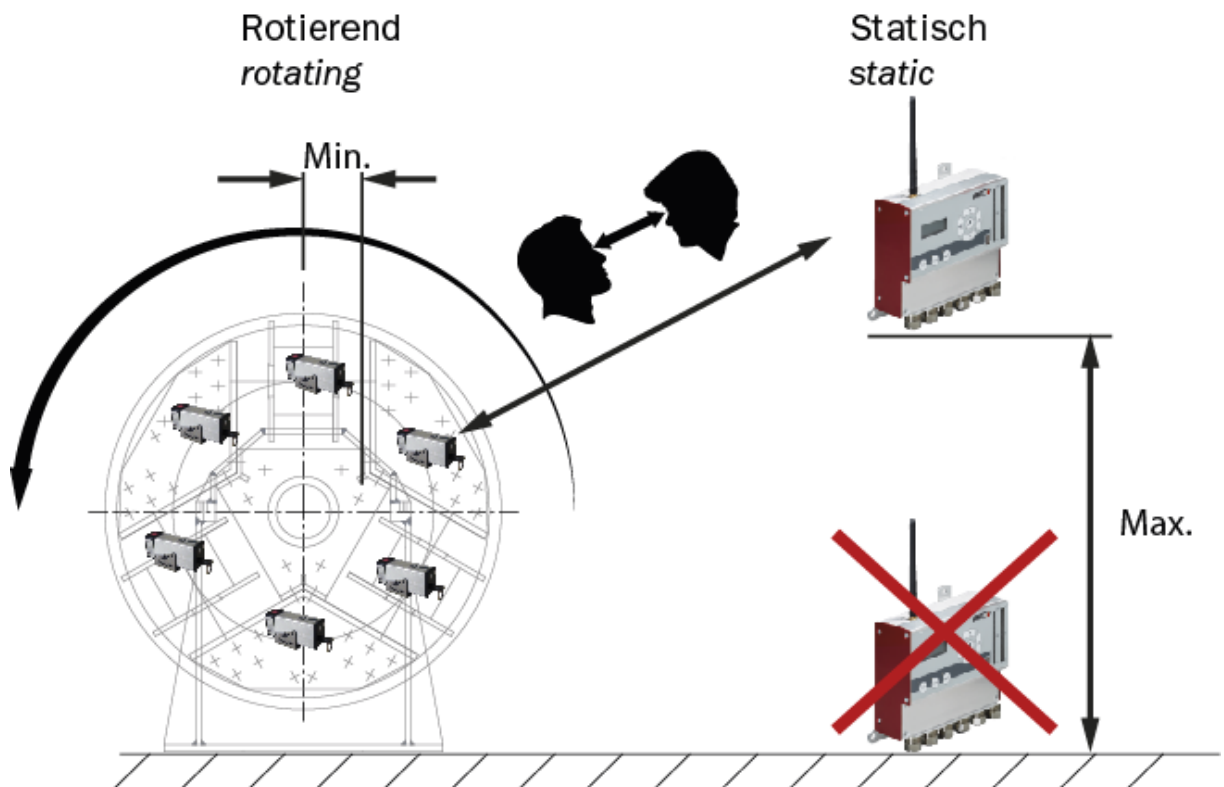
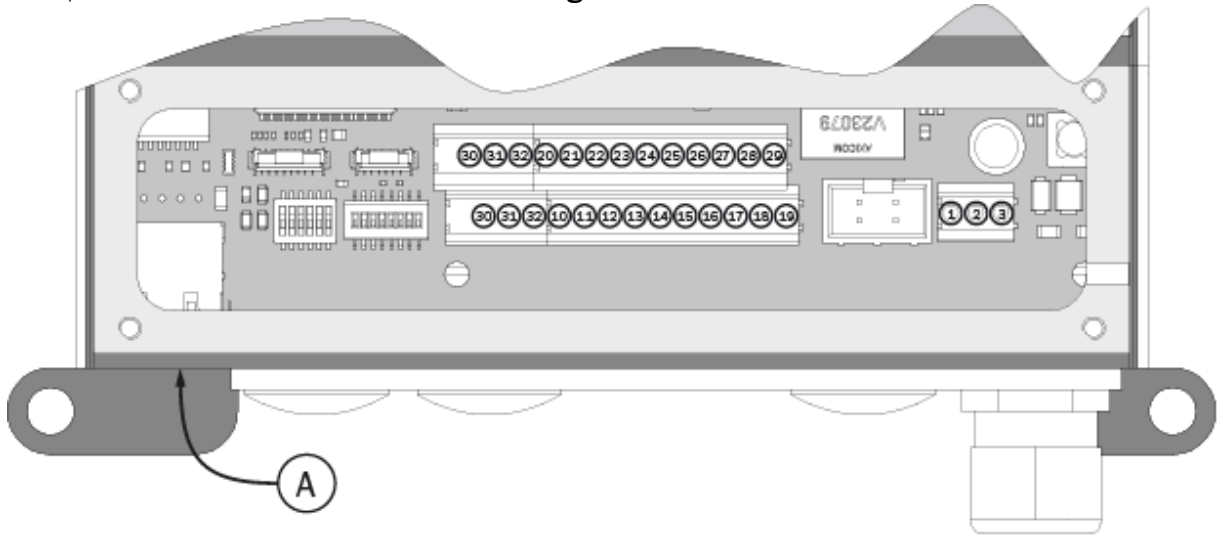

Figure 2: Electrical connection

FMS-cradleGUARD_BA_Manual.ai

Electrical connection	
Item	Description
1	24 VDC (18 to 36 VDC)
2	GND
3	PE
16, 26	Relay 1/1 - 1/2
17, 27	Relay 2/1 - 2/2
18, 28	Relay 3/1 - 3/2
19, 29	Relay 4/1 - 4/2
A	RJ45 socket for Ethernet

Table 2: electrical connection RTM X42.BC.T/R

4.3 Specifications for sensors and switches

Optionally four switches/sensors can be connected to the brake actuator. Their signal is transmitted to the RTM X42.CC Control Center where the status is displayed.

There are some specifications for sensors that must be met to guarantee full functionality of the system.

We recommend a cable with 3 x 0.5 mm² for the sensor connection. The cables must be routed separately from power cables.

Specification sensors and switches	
Feature	Description
Time delay before availability	≤ 50 ms
Current drain	As small as possible, 10 to 15 mA
Power supply	10 to 36 VDC
Dimensions	Length between 30 to 70 mm
Electrical connection	Open cable ends, no connector

Table 1: specifications sensors

Sameples sensors						
OEM	Type	Output	M8 flush	M8 n. flush	M12 flush	M12 n. flush
IFM	PNP	NO	IE5121	–	IF5297	IF5329
IFM	PNP	NO	IE5072	–	IF5188	IF5249
IFM	NPN	NO	IE5123	–	IF5305	IF5337
IFM	NPN	NO	IE5082	–	IF5200	IF5251
IFM	PNP	NC	IE5122	–	IF5301	IF5333
IFM	PNP	NC	IE5078	–	IF5219	IF5250

Table 2: example list sensors, to be completed

FMS_cradleGUARD

Ausgang

Öffner

Output

NC Normally Closed

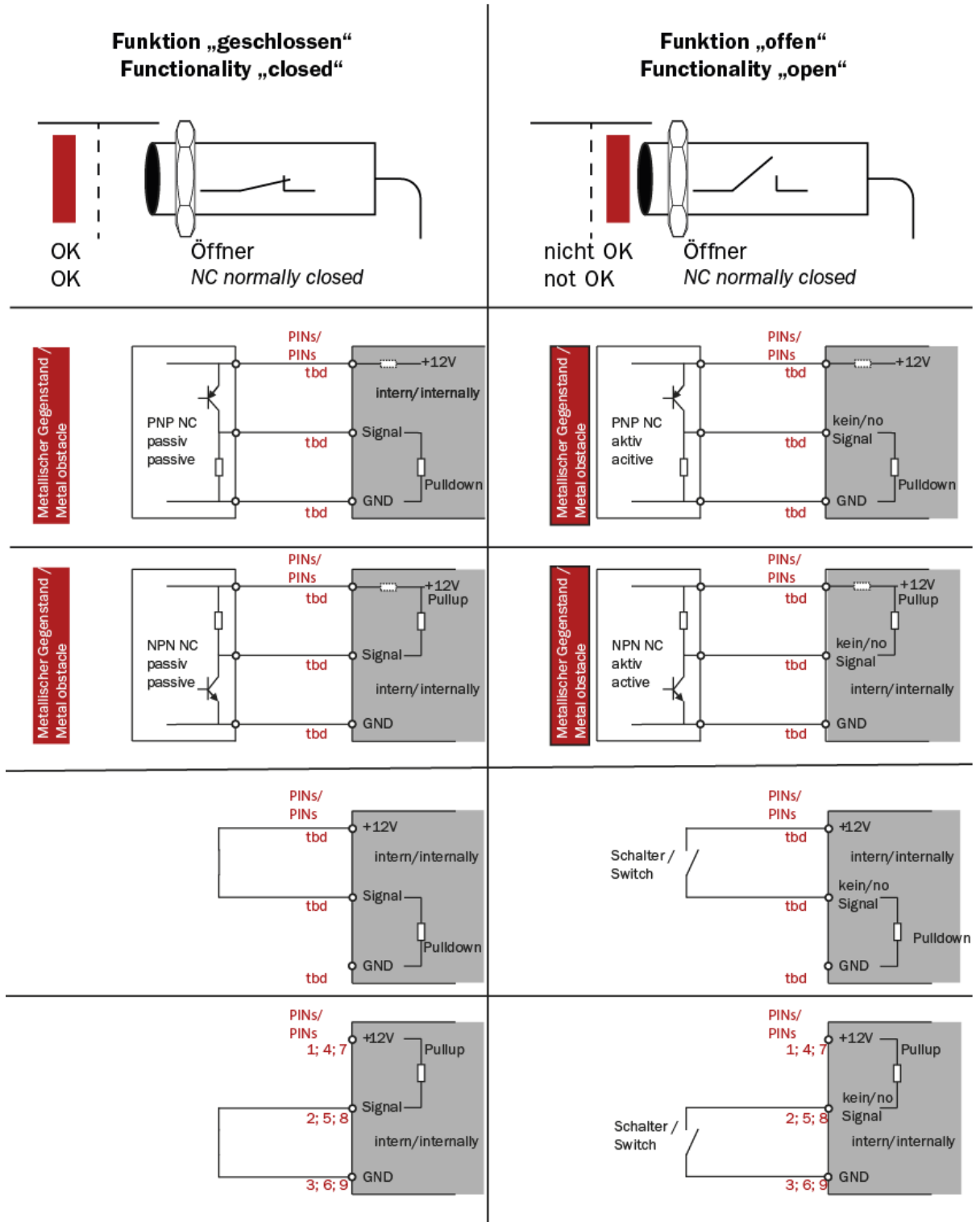

Figure 2: sensor connection Normally Closed

FMS_cradleGUARD_BA_Manual.ai

Ausgang

Schliesser

Output

NO Normally Open

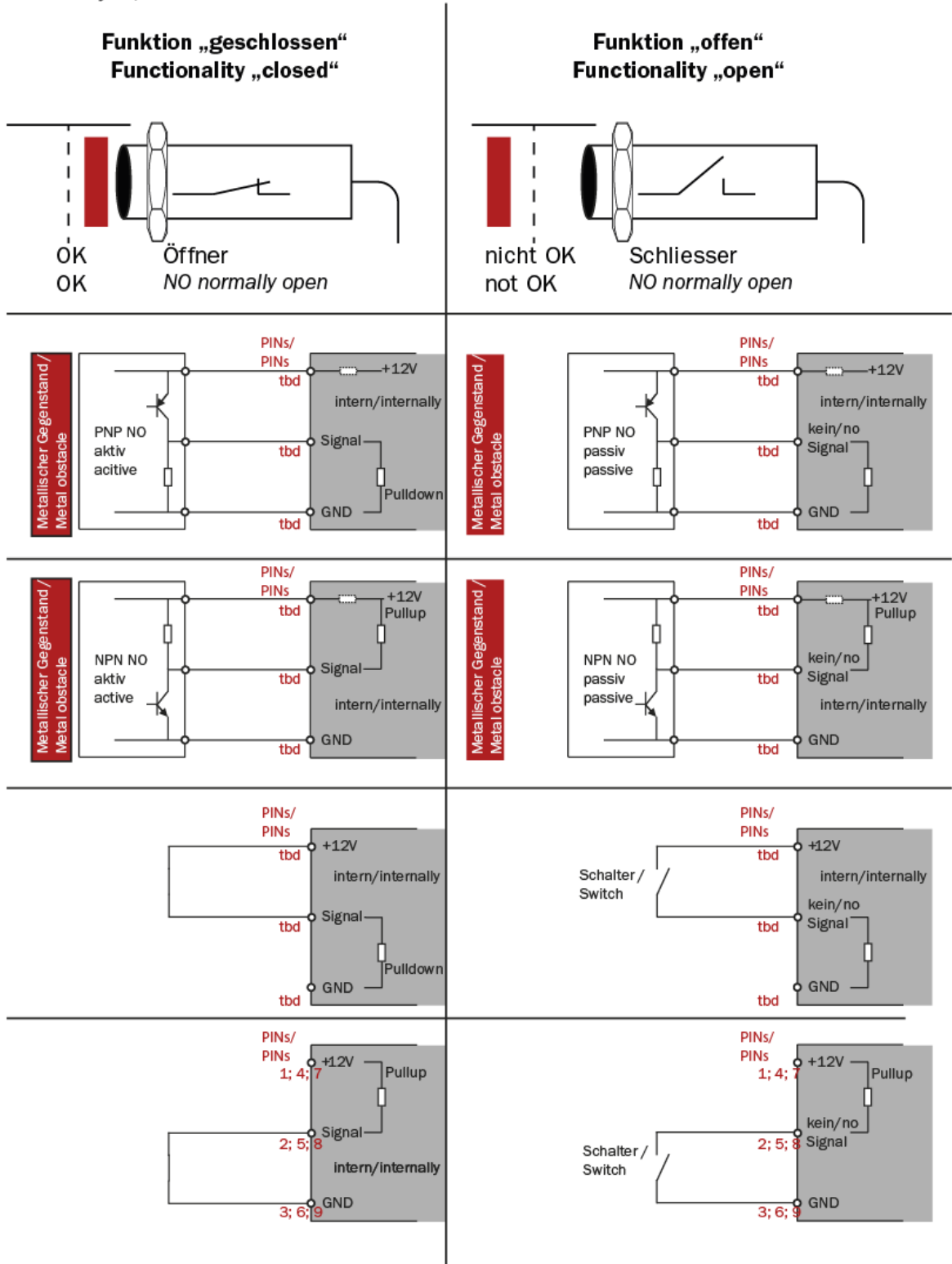

Figure 3: sensor connection Normally Open

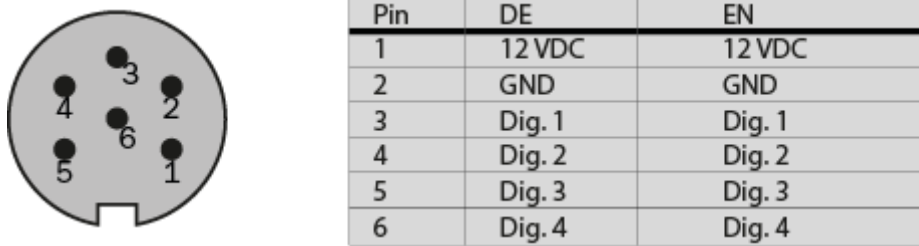

Figure 3: Pin assignment digital inputs brake actuators RTM_X42_BC_BA_Manual.ai

4.4 Configuration of relay outputs for sensors and switches

The transceiver module RTM X42.BC.T/R features 4 relay outputs that can be triggered by the status of digital inputs.

The relay outputs can be configured via the integrated web interface. To access the configuration menu, open a new browser window and enter the IP address of the transceiver module RTM X42.BC.T/R in the input field of the browser. E.g. <http://192.168.000.091>.



User interface language

The user interface of the browser is only available in English



Figure 4 Home

RTM_X42_BC_BA_Manual.ai

Web Interface – Home	
Item	Description
1	Main navigation

Table 3: Home

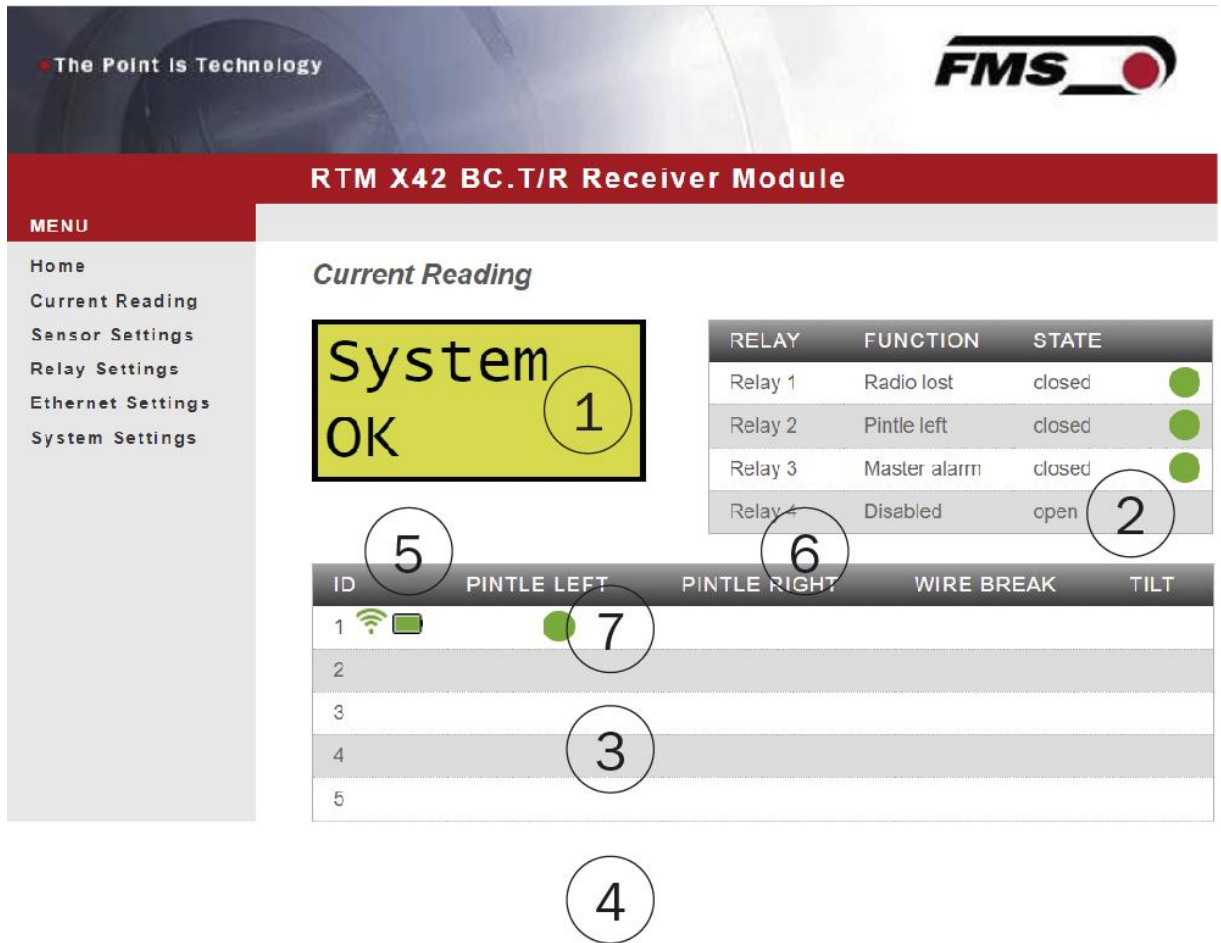

Figure 5: Current Reading RTM_X42_BC_BA_Manual.ai

This a purely informative page only. You cannot edit anything.

Web Interface – Current Reading	
Item	Description
1	Information on the display
2	Status indicator for relay outputs
3	List of sensors 1 to 21
4	List of sensors 22 to 42 (not illustrated) Depending on the zoom factor of the browser window, the tables can also be arranged among each other.
5	Column “ID” (IDentification) Every brake actuator has its own ID number for easy assignment. The ID can be found on a sticker on the housing.
6	Column with the respective function and status Pintle left/right If 2 pintles exist on the cradle, they can be differentiated here.

Web Interface – Current Reading	
Item	Description
7	Sensor status Green - OK Red - Fault

Table 4: Current Reading

The table always contains all available 42 brake actuators. Status messages are only displayed for the active brake actuators.

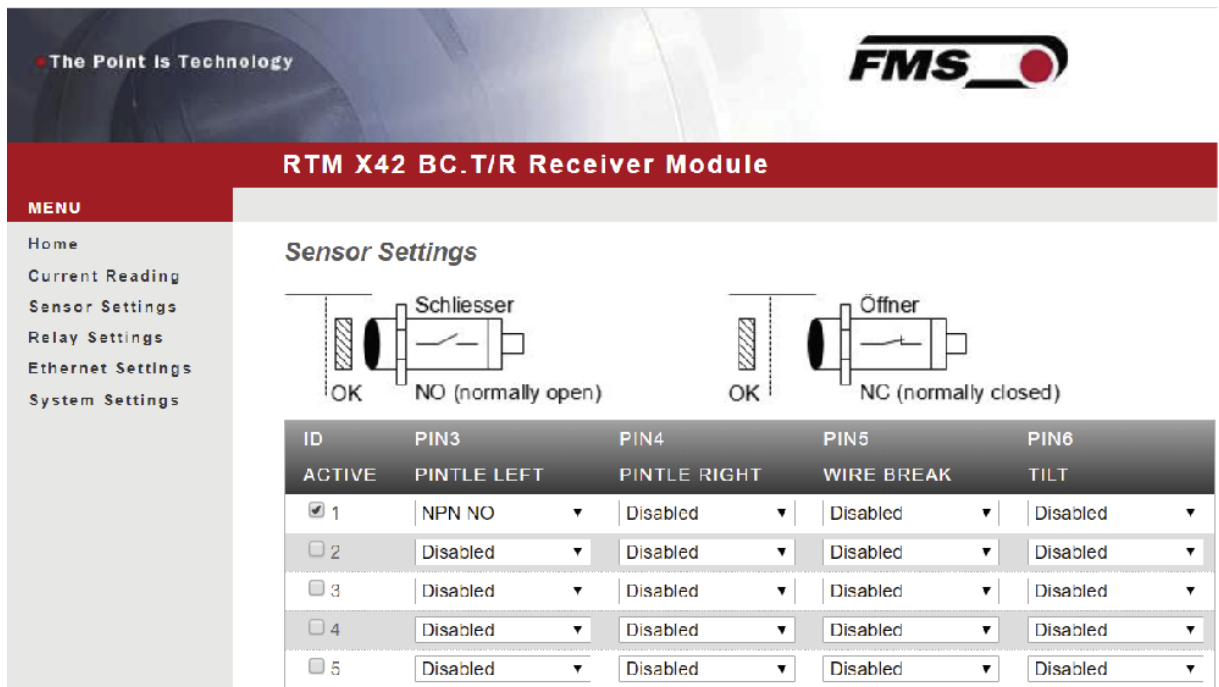

Figure 6: Sensor Settings

RTM_X42_BC_BA_Manual.ai

Web Interface – Sensor Settings	
Column	Description
ID ACTIVE	Indicates if the respective brake actuator is active. This is automatically set by the RTM X42.CC Control Center and cannot be modified here.
PIN3 PINTLE LEFT	The individual columns stand for the 4 sensors that can be connected per brake actuator. 5 different connection possibilities can be selected
PIN4 PINTLE RIGHT	
PIN5 WIRE BREAK	

PIN6 TILT	<p>Deactivated - Disabled</p> <p>No sensor is connected. The sensor status is not shown on the display.</p> <p>Normally open</p> <p>PNP NO: Sensor switches the positive signal (+12 V)</p> <p>NPN NO: Sensor switches ground (GND)</p> <p>Normally closed</p> <p>PNP NC: Sensor switches the positive signal (+12 V)</p> <p>NPN NC: Sensor switches ground (GND)</p>
------------------	--

Table 5: Sensor Settings



Saving changes

If you made changes, you must confirm them using “Save changes.” Otherwise, your entries will be discarded once you leave the page!

You may have to scroll down on the page to see the save key.

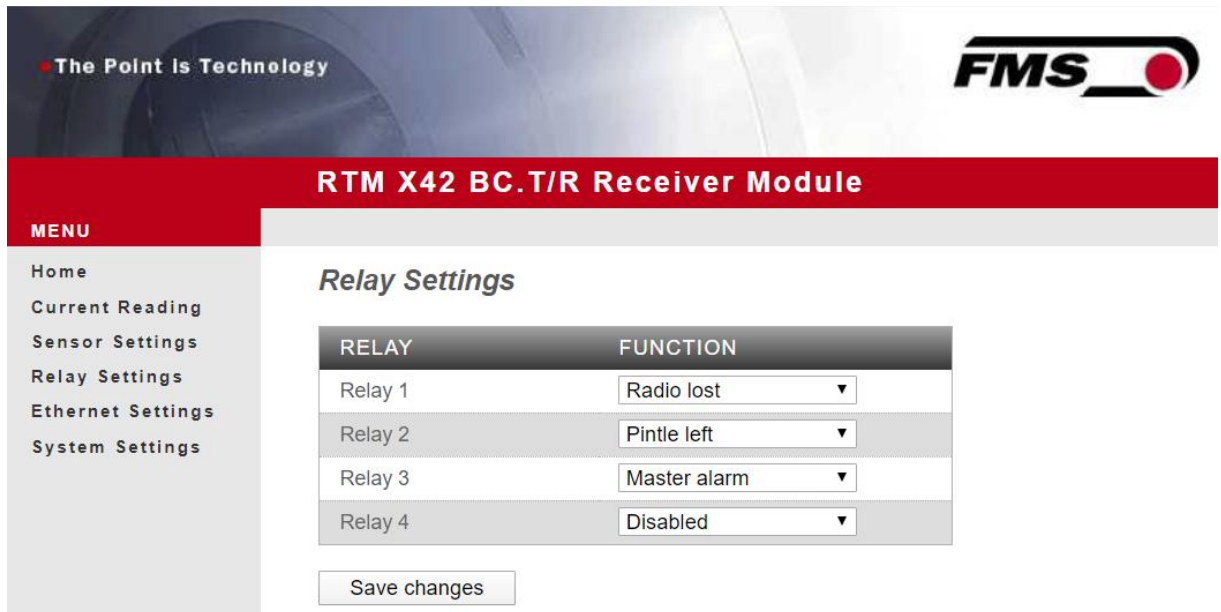

Figure 7: Relay Settings

RTM_X42_BC_BA_Manual.ai

You can define individual trigger conditions for the 4 relay outputs in the receiver module.

Web Interface – Relay Settings	
Function	Description
Disabled	Without function
Pintle left	If 2 pintles exist on the cradle, they can be differentiated here.
Pintle right	
Wire Break	Detection of a wire break using the respective sensor. The response time until relay triggering can be up to 8.4 seconds.
Tilt	Is mainly used for tubular type stranders and to detect cradle swinging.
Radio lost	The quality of the radio connection of the individual brake actuator is checked continuously. A relay can be switched in the case of a poor connection.
Battery low	Is activated if the charging status of the battery drops below 5%. A runtime of a few days is left prior to battery replacement. This alarm does not affect the Master alarm.
Master alarm	Is activated as soon as any fault state occurs, regardless of the configuration of other relay outputs.

Table 6: Relay Settings



Saving changes

If you made changes, you must confirm them using “Save changes.” Otherwise, your entries will be discarded once you leave the page!



Recommendation for Alarms

We recommend to select **at least the "Master alarm" and "Battery low" for the relay outputs.** The output of the "Master alarm" should be directly connected to the PLC to stop the machine in case of any alarm condition. The "Batter low" output can be connected to an indication light to remind the operator of changing the empty battery during the next production stop.

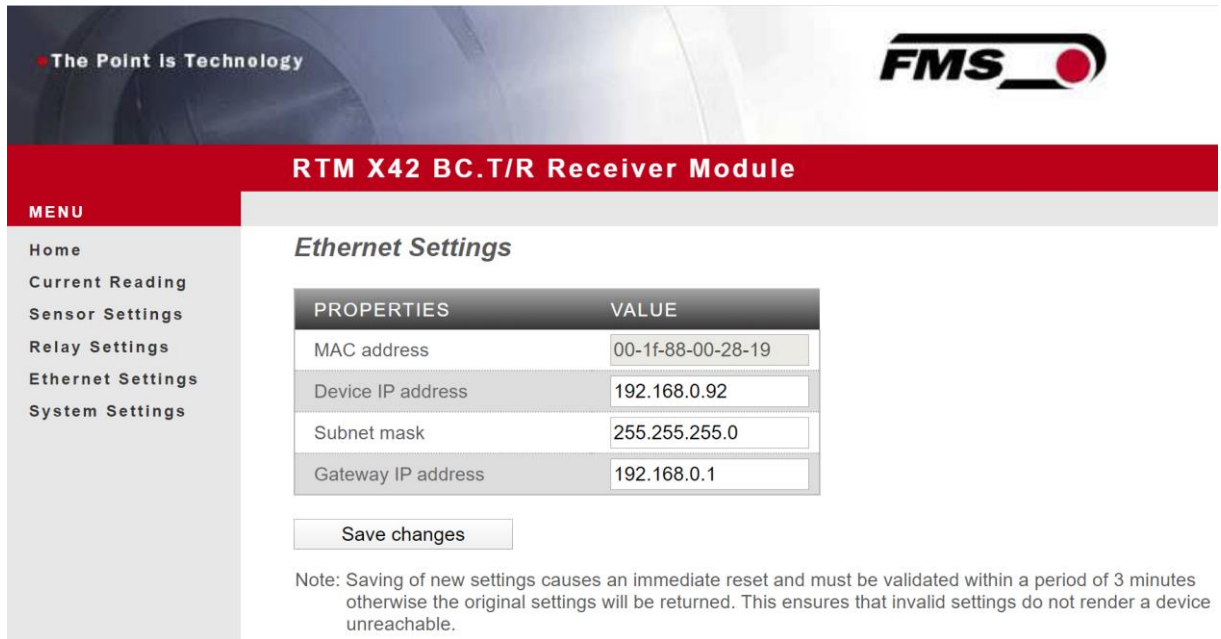

Figure 8: Ethernet Settings

RTM_X42_BC_BA_Manual.ai



Saving changes

If you made changes, you must confirm them using “Save changes.” Otherwise, your entries will be discarded once you leave the page!

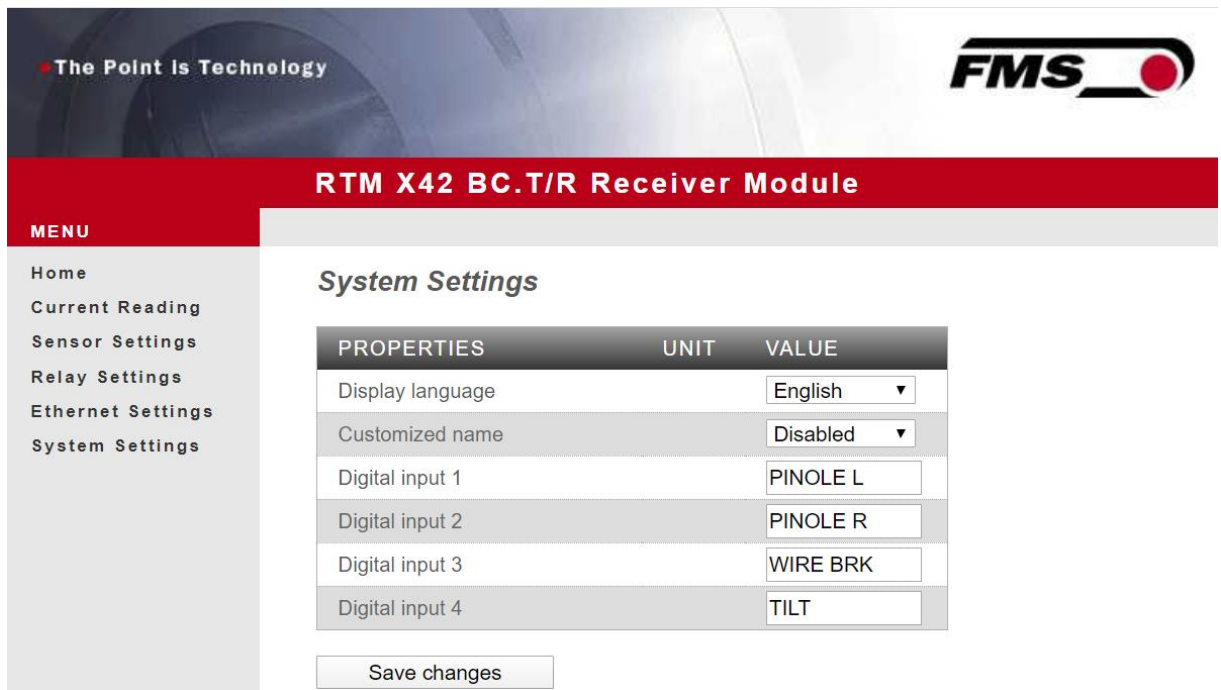

Figure 9: System Settings

RTM_X42_BC_BA_Manual.ai

System Settings	
Function	Description
Display language	Sets the language of the display of the RTM X42.BC.T/R
Customized Name	<p>Enabled</p> <p>You can enter your own names in the fields digital input 1 to 4.</p> <p>This does only affect the display on the device itself, not the browser surface.</p> <p>Disabled</p> <p>Pre-defined names will be used</p>
Digital input 1 to 4	You can assign names up to 8 digits

Table 7: System Settings



Consequences of changing names

If you have modified the names, the new names will appear in the drop-down menus of the previous pages and they will be visible in the display of the RTM X42.BC.T/R



Saving changes

If you made changes, you must confirm them using “Save changes.” Otherwise, your entries will be discarded once you leave the page!

4.5 Installation of RTM X42.BC.BA.XXX Brake Actuator

Installation sequence and arrangement are mainly defined by the installation situation at the machine.

The following points are considered notes regarding proper assembly only.

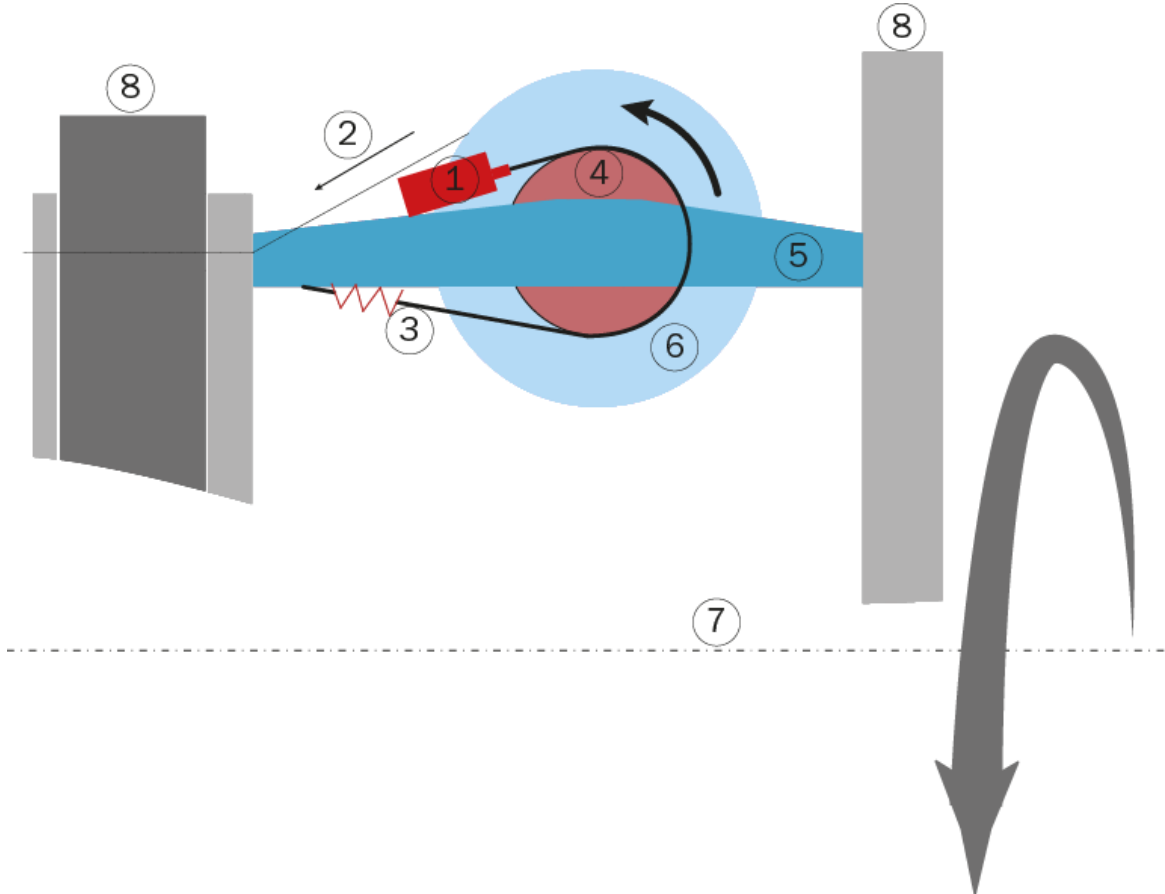

Figure 10: Installation concept for brake actuators using a cage-type stranding machine as an example
 RTM_X42_BC_BA_Manual.ai

Installation concept	
Item	Components
1	RTMX42.BC.BA.XXX Brake Actuator behind the brake disc (direction of rotation)
2	Strand from pay-off bobbin
3	Spring package before the brake disc (direction of rotation)
4	Brake disc
5	Spool cradle
6	Pay-off, spool
7	Rotation axle of the stranding machine

Table 8: installation concept

Note

An individual identification number (ID) is assigned to every brake actuator at the factory. These IDs can be found on a sticker on the respective housing.



If you would like to group individual strands (e.g., per cage, etc.), we recommend installing brake actuators with consecutive IDs for such groups.

Using a different assignment of the IDs to the respective channels, you can still change the assignment later on in the RTMX42.CC Control Center, however, this causes additional effort.

- Prior to installing the brake actuator, ensure that the original path of the brake rope or belt is preserved if possible.
- If additional struts or components are required for optimum assembly, you should ensure that these are sturdy and firmly connected to the cradle and/or the machine.
- The bore pattern in the assembly bracket as well as the possible rotation of the assembly bracket by 180 degree allow for a certain height and angle compensation during assembly.
- Extend the brake actuator completely prior to assembly. With the battery pack inserted, you can extend the brake actuator by pressing the  button. The brake actuator stops automatically on reaching the end position.

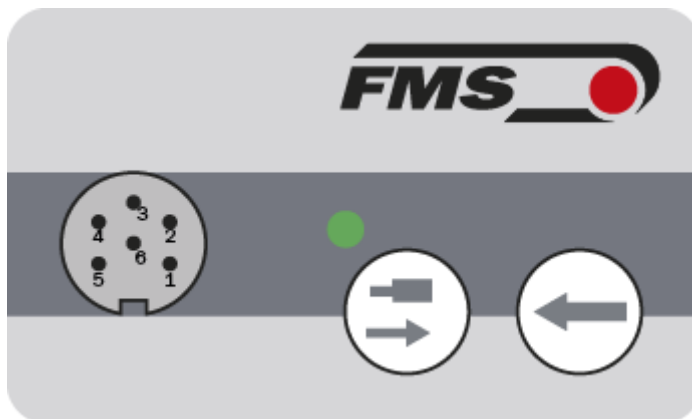



Figure 11: Buttons on brake actuator

- Hold the brake actuator with pre-assembled assembly bracket to the designated location and mark the position of the assembly bracket on the cradle.
- Consider any possible elasticity of the brake rope/belt.
- Attach the assembly bracket to the cradle using at least two M8 screws.
- Bolt the brake actuator to the bracket using the two collar screws. Note that the screws are of different length and need to be fitted on the correct side.
- Connect the brake rope/belt to the brake actuator. You can use the enclosed shackle for this purpose.
- Retract the brake actuator using the  button. The brake actuator aligns itself at the optimum angle.

- Fully tighten the collar screws. The brake actuator should now be fixated in the bracket.
- If the brake rope/belt is not sufficiently tensioned with the brake actuator completely retracted, you must shorten the cable/band.



Note

Installing the brake actuator on one side of the cradle shifts the center of gravity. To reduce wear of machines with back twist, we recommend checking for this shift and attaching counterweights as compensation as needed.

4.5.1 Sizing of spring, spring package

To ensure optimum control performance, the spring assembly should be selected so that the maximum braking force is applied at the maximum stroke of the brake actuator (40 mm).

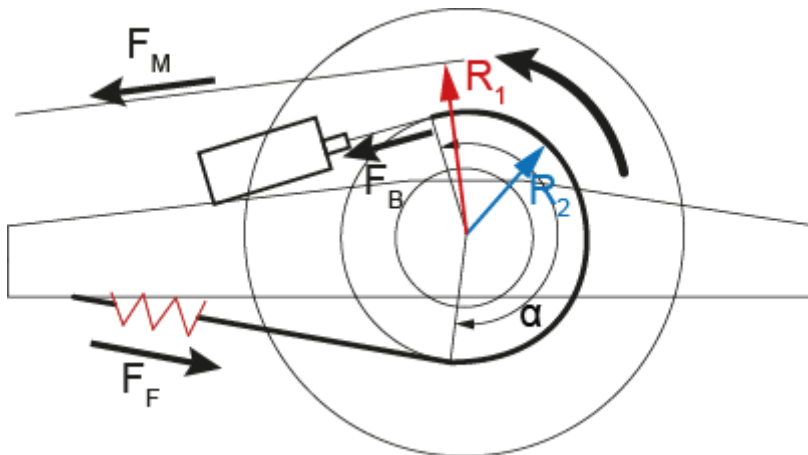

Figure 12: forces, moments on the pay-off

μ friction coefficient between brake rope and brake disc

α wrap angle in arc measure

F_M material tension on the wire / strand in N

F_F spring force in N

F_B brake force in N

$$\sum M = 0 \rightarrow F_M * R_1 = F_F * R_2 \rightarrow F_F = F_M * R_1 / R_2$$

$$F_B < F_F \rightarrow F_B = F_F * e^{-\mu * \alpha}$$

Beispiel

$$\mu = 0.25$$

$$\alpha = 255^\circ$$

$$F_M = 1000 \text{ N}$$

$$R_1 = 50 \text{ mm}$$

$$R_2 = 30 \text{ mm}$$

$$F_F = 1000 \text{ N} * 50 \text{ mm} / 30 \text{ mm} = 1'666.67 \text{ N}$$

$$F_B = 1666.67 \text{ N} * e^{-0.25 * 1\frac{1}{4} \pi} = 624.4 \text{ N}$$

5 Manual Operation of the Brake Actuators

Closed-loop control is only possible in connection with the RTM X42 Telemetry System and the system extension RTM X42.CC Control Center. However, the individual brake actuators can also be manually controlled.

The buttons can be found on the housing.





Manual operation of the brake actuators	
<i>button</i>	<i>Action</i>
	Extension of the brake actuator
	Retraction of the brake actuator
 + 	By pressing both buttons at the same time, the brake actuator approaches a defined tension (reference brake force).

Table 9: operation of brake actuators

The brake force is measured internally using a force sensor in the brake actuator. The standard values can be found in the following table.

Reference brake force factory settings	
Brake actuator type	Value
RTM X42.BC.BA.600	100N
RTM X42.BC.BA.2500	450N

Table 10: reference brake force

6 Maintenance

The brake actuators are maintenance-free. If repairs are necessary, we recommend contacting FMS Customer Service and sending the affected components for revision to FMS.

7 Dimensions

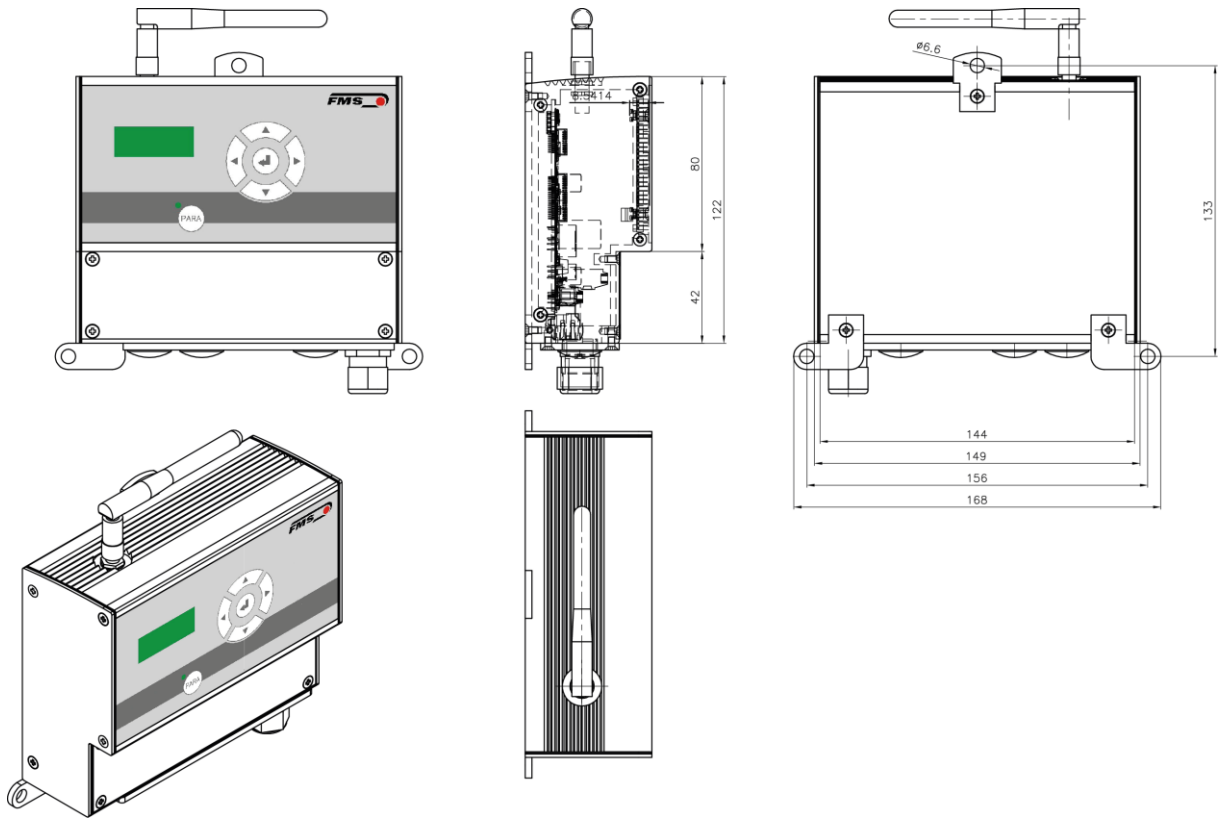

Figure 13: Dimensions of RTMX42.BC.T/R Transceiver RTM_X42_BC_BA_Manual.ai

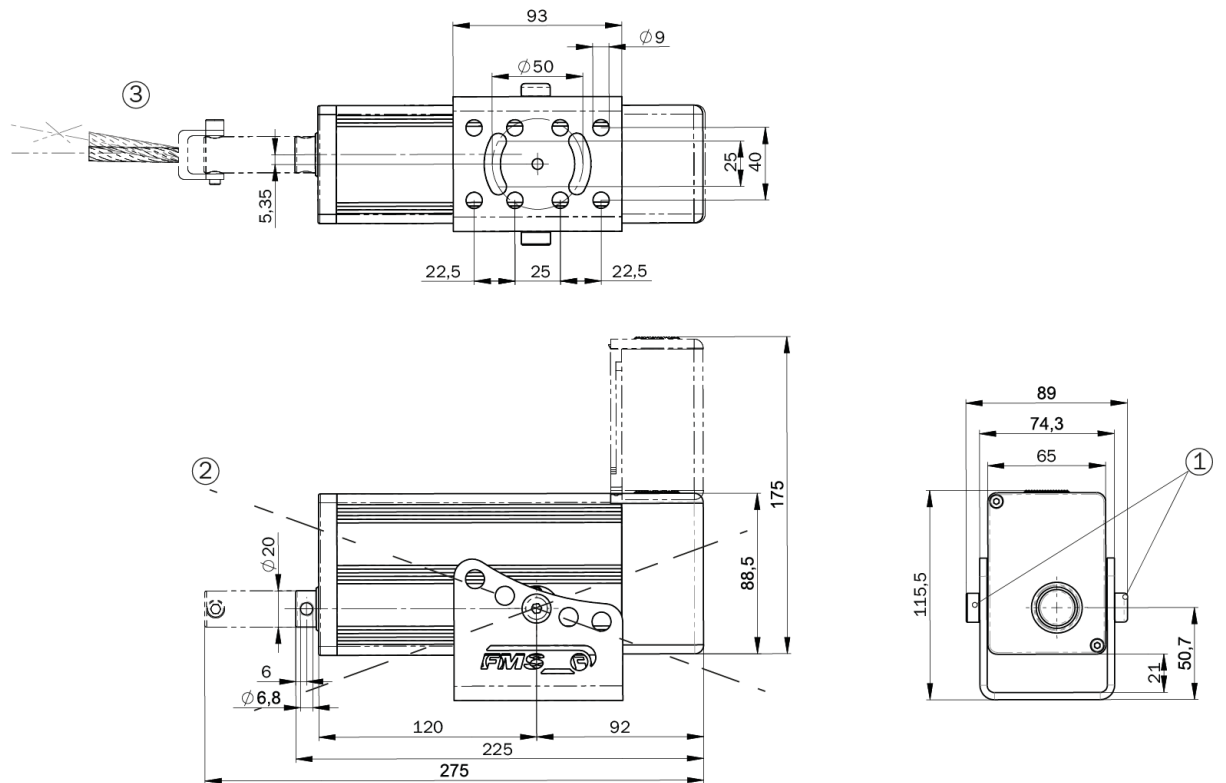

Figure 14: RTM X42.BC.BA.600 dimensions RTM_X42_BC_BA_Manual.ai

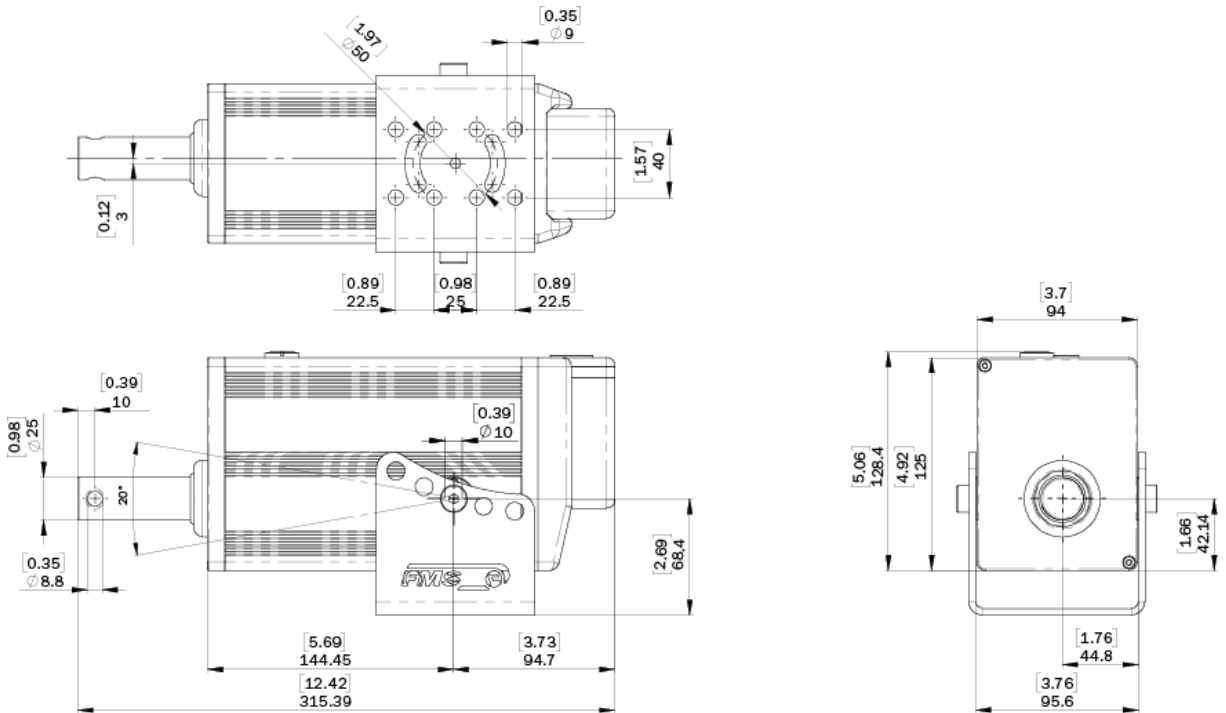

Figure 15: RTM X42.BC.BA.2500 dimensions

RTM_X42_BC_BA_Manual.ai

Designation	
Item	Description
1	Collar screw
2	Swiveling range $\pm 20^\circ$
3	Observe axial alignment of brake actuator and brake rope/belt

Table 11: designation

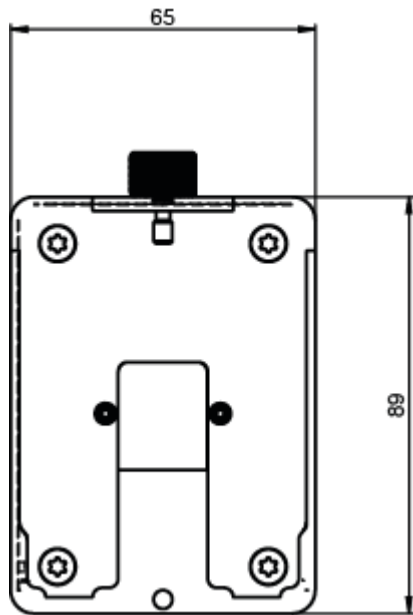
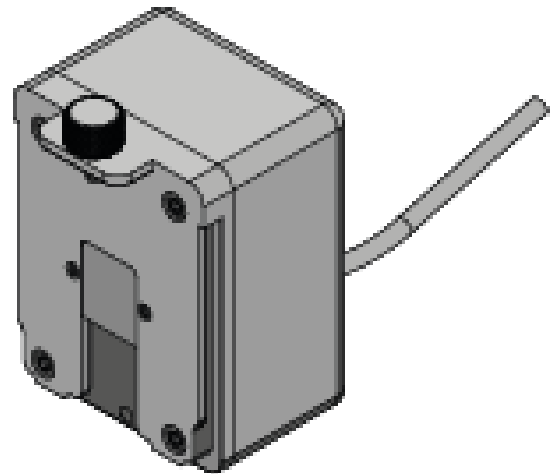

Figure 16: 24VDC Adapter



RTM_X42_BC_BA_Manual.ai

8 Technical Data

8.1 RTM X42.BC.T/R Transceiver

Technical data RTM X42.BC.T/R Transceiver	
Description	Value
Number of channels	Control of up to 42 individual brake actuators
Display and operation	Modification of IP address via operating panel and display of signal quality
Propagation delay	8400 ms (at least 200 mm per brake actuator)
Control interface	Ethernet via web browser
Radio interface	2.44 GHz
Power supply	24 VDC (18 to 36 VDC) / 10 W (max. 0.5 A)
Temperature range	0 to 50 °C [32 to 122 °F]
Protection class	IP 52
Weight	0.65 kg [1.43 lb]

Table 12: technical data RTM X42.BC.T/R

8.2 RTMX42.BC.BA.600 Brake Actuator

Technical data RTMX42.BA.600 brake actuator	
Description	Value
Maximum brake force	600 N [135 lbf]
Maximum stroke	40 mm/1.6 in.
Battery pack	Li Ion, 10.2 Ah, 7.2 V
Radio interface	2.44 GHz
Temperature range	0 to 50 °C [32 to 122 °F]
Drive train	Stepper motor and spindle maintenance and wear free
Speed	1.5 mm/sec, 0.06 in/sec.
Protection class	IP 52
Weight	Drive unit: 1.7 kg [3.75 lb]; battery-pack: 0.5 kg [1.1 lb]; bracket: 0.5 kg [1.1 lb]; Clevis: 0.03 kg [0.07 lb]

Table 13: technical data RTM X42.BC.BA.600

8.3 RTMX42.BA.2500 Brake Actuator

Technical data RTMX42.BC.BA.2500 brake actuator	
Description	Value
Maximum brake force	2500 N [560 lbf]
Maximum stroke	40 mm/1.6 in.
Battery pack	Li Ion, 10.2 Ah, 7.2 V
Radio interface	2.44 GHz
Temperature range	0 to 50 °C [32 to 122 °F]
Drive train	Stepper motor and spindle maintenance and wear free
Speed	1.5 mm/sec, 0.06 in/sec.
Protection class	IP 52
Weight	Drive unit: 2.3 kg [5.05 lb]; battery-pack: 0.5 kg [1.1 lb]; bracket: 0.5 kg [1.1 lb]; Clevis: 0.03 kg [0.07 lb]

Table 14: technical data RTM X42.BC.BA.2500

8.4 24VDC Adapter for brake actuator RTM X42.BC.BA.24VDC

Technical data 24VDC adapter	
Description	Value
Power supply	18 to 36VDC
Required power	25W for brake actuator RTM X42.BC.BA600 50W for brake actuator RTM X42.BC.BA250

Tabelle 3: technical data 24VDC adapter

8.5 Radio Certification ETSI

Certified tests (copy of certificates provided upon request)	
RTM X42.BC	5.3 Radio Certification ETSI
Magnitude of Test (Coverage)	Article 3.2 of Directive 1999/5/EC (R & TTE Directive)
Certification	ETSI EN 300 440-2 V1.5.1 (2009-03); ETSI EN 300 440-1 V1.3.1 (2009-03)
RTM X42	FCC Certification USA, Canada
Magnitude of Test (Coverage)	Class A digital device, pursuant to Part 15 of the FCC Rules
Certification	FCC Registration #: 0020311882
RTM X42	CAB Radio Certification for Japan
Magnitude of Test (Coverage)	Low power data communi. FXD; Art. 38 - 24, Paragraph 1 of radio law
Certification	Article 2, Clause 1 Item 19, Certification ID #: 202WWSM10126721

8.6 Lloyd's Register Type Approval

Certificate available upon request



FMS Force Measuring Systems AG
Aspstrasse 6
8154 Oberglatt (Switzerland)
Tel. 0041 1 852 80 80
Fax 0041 1 850 60 06
info@fms-technology.com
www.fms-technology.com

FMS USA, Inc.
2155 Stonington Avenue Suite 119
Hoffman Estates,, IL 60169 (USA)
Tel. +1 847 519 4400
Fax +1 847 519 4401
fmsusa@fms-technology.com

FMS Italy
Aspstrasse 6
8154 Oberglatt (Switzerland)
Phone +39 02 39487035
fmsit@fms-technology.com