



Installation Instruction UMGZP

Force measuring block with increased stiffness as drop-in replacement for Philips series PR 9951

Document version 2.10

Issue date / Author 09/2020 NS



**Diese Montageanleitung ist auch in Deutsch erhältlich.
Bitte kontaktieren Sie Ihre FMS Vertretung.**

1 Table of contents

1	TABLE OF CONTENTS	2
2	SAFETY INSTRUCTIONS.....	3
2.1	Presentation of safety information	3
2.1.1	Danger that could result in minor or moderate injuries.....	3
2.1.2	Note regarding proper function	3
2.2	General safety information	3
3	PRODUCT INFORMATION.....	4
3.1	Product description	4
3.2	Functional description	4
3.3	System arrangement.....	5
3.3.1	Horizontal measuring block	5
3.4	Scope of delivery.....	7
3.5	Order code	7
4	INSTALLATION.....	8
4.1	Installation conditions.....	8
4.2	Preparing the machine frame.....	8
4.3	Electrical connections	8
4.1	Sensitivity of 0.5 mV/V	9
5	TECHNICAL DATA	10
6	DIMENSIONS IN MM (IN.)	11

2 Safety instructions

All safety related regulations, local codes and instructions that appear in the manual or on equipment must be observed to ensure personal safety and to prevent damage to the equipment connected to it. If equipment is used in a manner not specified by the manufacturer, the protection provided by the equipment may be impaired.

Do not stress the equipment over the specification limits neither during assembly nor operation. To do so can be potentially harmful to persons or equipment in the event of a fault to the equipment.

2.1 Presentation of safety information

The following safety symbols appear in this manual.

2.1.1 Danger that could result in minor or moderate injuries



Danger, warning, caution

Failure to follow wiring instructions in this manual may result in equipment damage or personal injury.

2.1.2 Note regarding proper function



Note

Note regarding proper operation
Simplification of operation
Ensuring function

2.2 General safety information



The force sensors may not be stressed over the specification limits neither during assembly nor operation. The unit's overload protection value may not be exceeded.



The attachment points for the force sensors on the machine frame must be properly designed. The pillow blocks need to be appropriately mounted.

3 Product information

3.1 Product description

The force sensors of the UMGZP-Series, designed for the measurement of web tension on continuous processing lines, are used in combination with standard pillow blocks. They are designed as drop-in replacement for the discontinued Philips PR 9951 series. Block mounting is simple utilizing four fasteners into the bottom surface. The UMGZP force measuring blocks feature exceptional durability and operational reliability. Constructed of stainless steel and with their high overload protection these rugged products provide accurate web tension measurement even under the most stringent requirements. They are used in any application where an easy access to and fast change of rollers is vital.

3.2 Functional description

Standard pillow blocks are installed on the force measuring blocks of the UMGZP-Series. This design combines force sensor and bearing seat and allows for easy maintenance or exchange of the blocks, bearings and roll. The substantial overload protection translates to eliminated / minimized calibration issues due to machine upset conditions. The design includes dual bending beams, and this serves to eliminate the load specific influence of torque. The movement of the bending beams, which is proportional to the applied force, is detected by strain gauges arranged in a full bridge circuit and then converted into an electrical signal. This simple measurement principle delivers precise results even with low material tension and small web wrap angles. The Red Point, as located on the sensor body, should be aligned with the direction of the resultant force due to web tension.

3.3 System arrangement

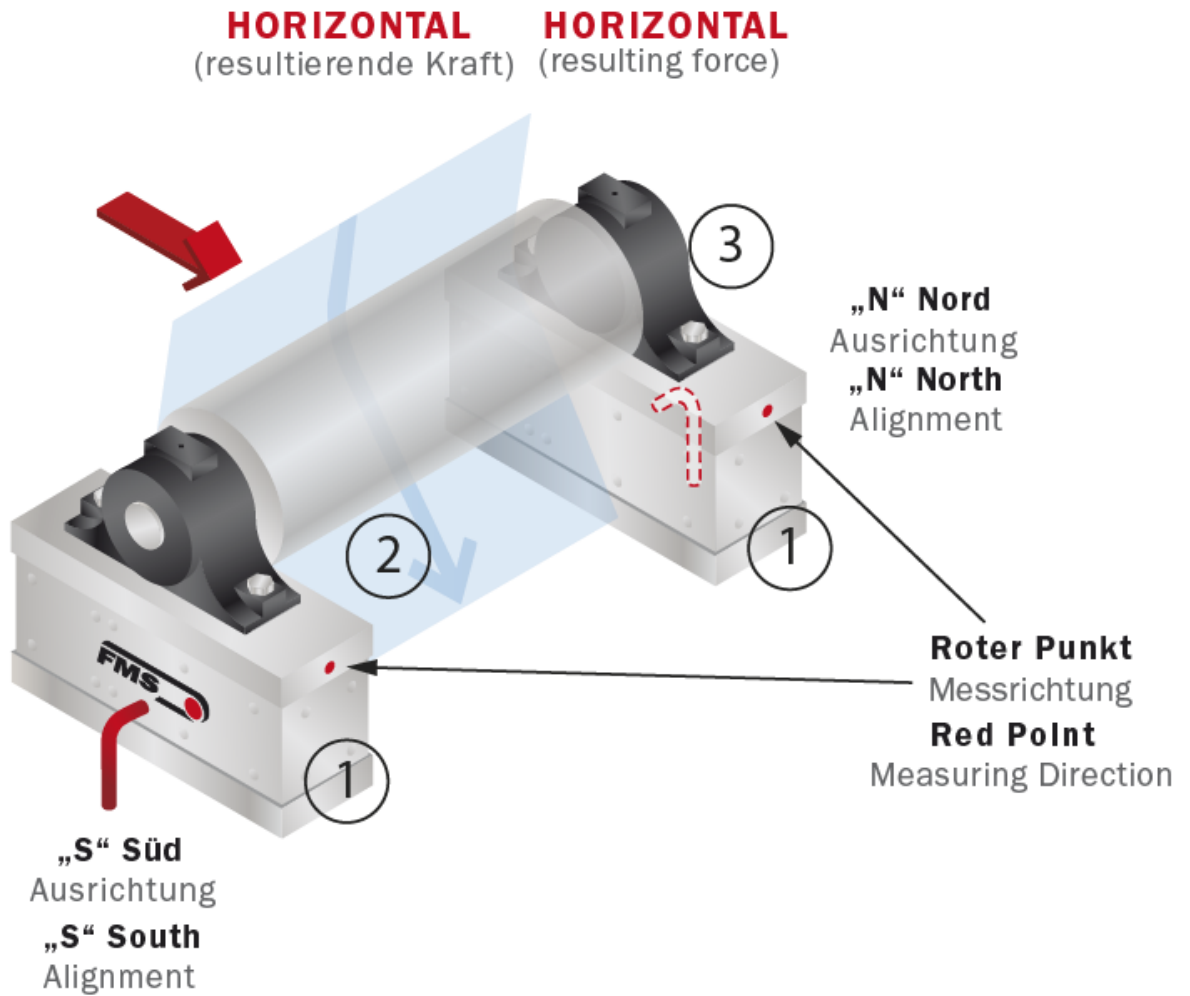
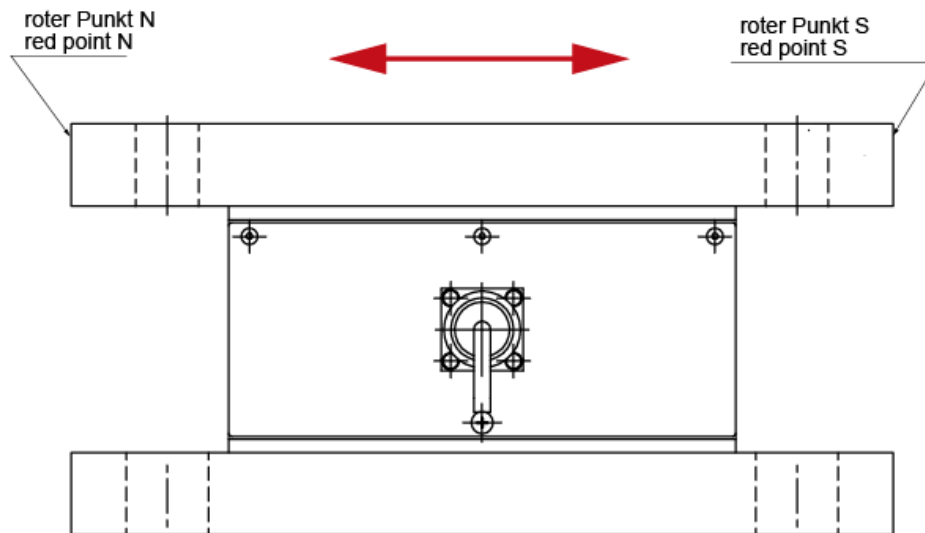

Illustration 1: arrangement of force sensors

UMGZP_BA_Manual.ai

System arrangement	
Position	Description
1	Force sensors (electrical connections are not displayed)
2	Web with moving direction
3	Left pillow block with shaft and roller

3.3.1 Horizontal measuring block



Nur Horizontaler Messblock - Orientierung roter Punkt in Abhängigkeit von elektrischem Anschluss
only horizontal measuring block - red point orientation depending on electrical connection

Illustration 2: Side view of horizontal version with measuring direction
UMGZP_BA_Manual.ai

3.4 Scope of delivery

Included:

force sensor, straight, waterproof connector (female)

Options

H14 right-angle connector in scope of supply, replaces straight connector

H16 temperature range up to 120 °C (248 °F)

H21 electrical connection with PG gland with 5 m (16 ft.) cable, replaces connector

H33 temperature range up to 150 °C (302 °F), with pg-gland and 5 m (16 ft.) cable

Accessories

prefabricated cable (specify length) with connector (straight or right-angle)

3.5 Order code

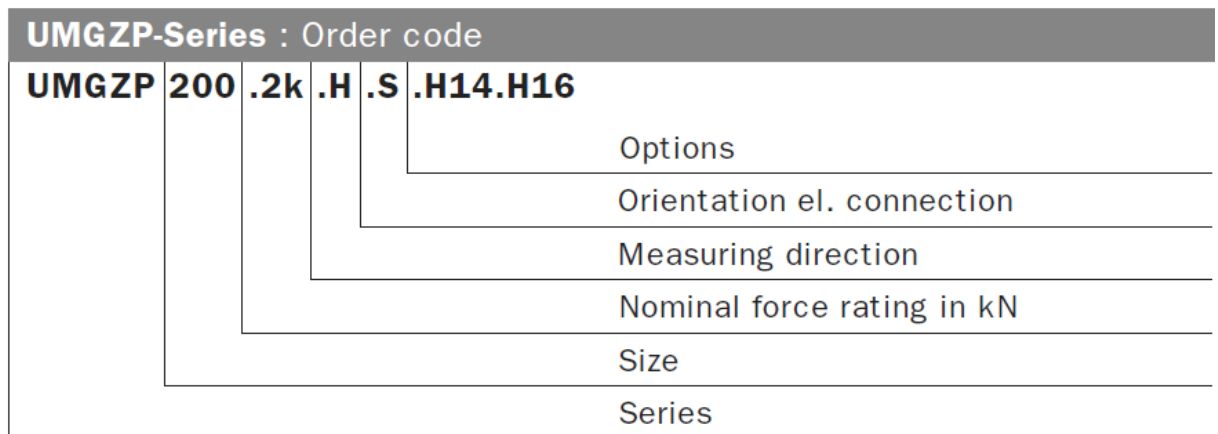

Illustration 3: Ordering code

Datasheet_UMGZP_series.indd

4 Installation

4.1 Installation conditions

Force sensors are defined as “partly completed machinery” according to the Directives 2006/42/EC, article 2. In order to assure a proper functionality of the parts and assure the essential safety requirements of operators working with it, the following conditions for the assembly must be met:



The Force Measuring Rollers may not be stressed over the specification limits neither during assembly nor operation. The unit's overload protection value may not be exceeded.



The mounting points for the Force Measuring Rollers on the machine frame must be properly designed. The bearings need to be appropriately mounted.



For proper installation and operation, follow the electrical wiring diagram and instructions in this manual.

4.2 Preparing the machine frame

Two force sensors are required to equip a measuring roller. For the installation of each block an even surface with the respective bore pattern needs to be prepared on the machine frame.

The contact surfaces for both force sensors must be even and aligned in the same height to ensure proper alignment of the measuring roller.

The Red Point indicated the direction where a applied force will generate a positive signal.

The design will allow the easy installation of a pillow block. With a customized adapter plate the force sensor will be able to hold any other type of roller supports.

The roller support needs to be realized with fixed and a floating bearing side.

4.3 Electrical connections

Connection between the force sensors and the amplifier is realized by means of a 4-pole cable with a cross-section of 0.25mm². The cable must be installed separate from power lines.

The shield needs to be connected to the amplifier only.

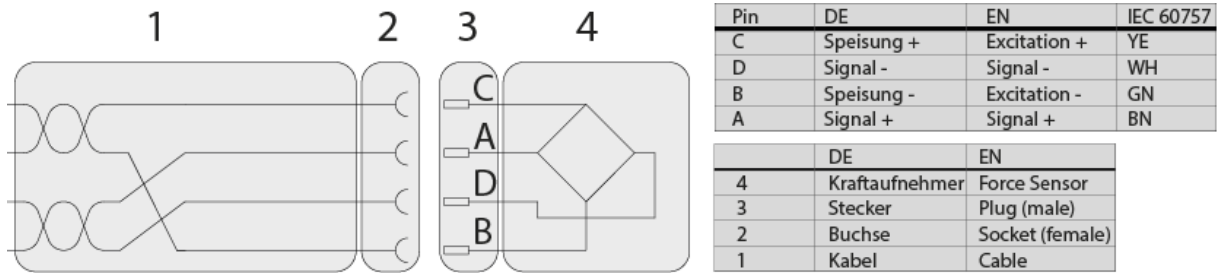

Polbild, Ansicht Stift-/ Steckerseite
Pin assignment, top view male connector

Farbangaben (IEC60757) und Codierung gelten nur für FMS Komponenten!
Color scheme (IEC60757) and pin codes are valid for FMS components, only!

Illustration 4: electrical connection
Pin_Assignment_Sensorkabel_Farben_Stecker.ai

4.1 Sensitivity of 0.5 mV/V



Special measuring amplifiers

With these force sensors, FMS recommends the combination with measuring amplifiers with the option V05

If you are using a regular measuring amplifier without option V05:



Scaling of measuring signal, gain factor

Especially for small wrap angles you should increase the parameter "system force" in the measuring amplifier by factor 3.6.

This will provide a significantly improved output signal.

Example

You are using two forces measuring blocks with 3000 N nominal force each. This results in a system force of $2 \times 3000 \text{ N} = 6000 \text{ N}$.

WE recommend to adjust the system force to $3.6 \times 6000 = 21600 \text{ N}$

5 Technical data

Sensitivity	0.5 mV/V
Tolerance of the sensitivity	<± 0.2 %
Accuracy class	±0.5 % of nominal force
Temperature coefficient	±0.1 %/10K
Temperature range	-10 bis to 60 °C (14 to 140 F)
Input resistance	350 Ω
Excitation voltage	1 to 7 VDC
Overload protection	10-times nominal force
Material sensor body	Stainless steel
Protection rating	IP42
Electrical connection	Male flange connector, Amphenol 4-pole
Repeatability error	0.05%
Measuring range	30:1

Table 1: Technical data

6 Dimensions in mm (in.)

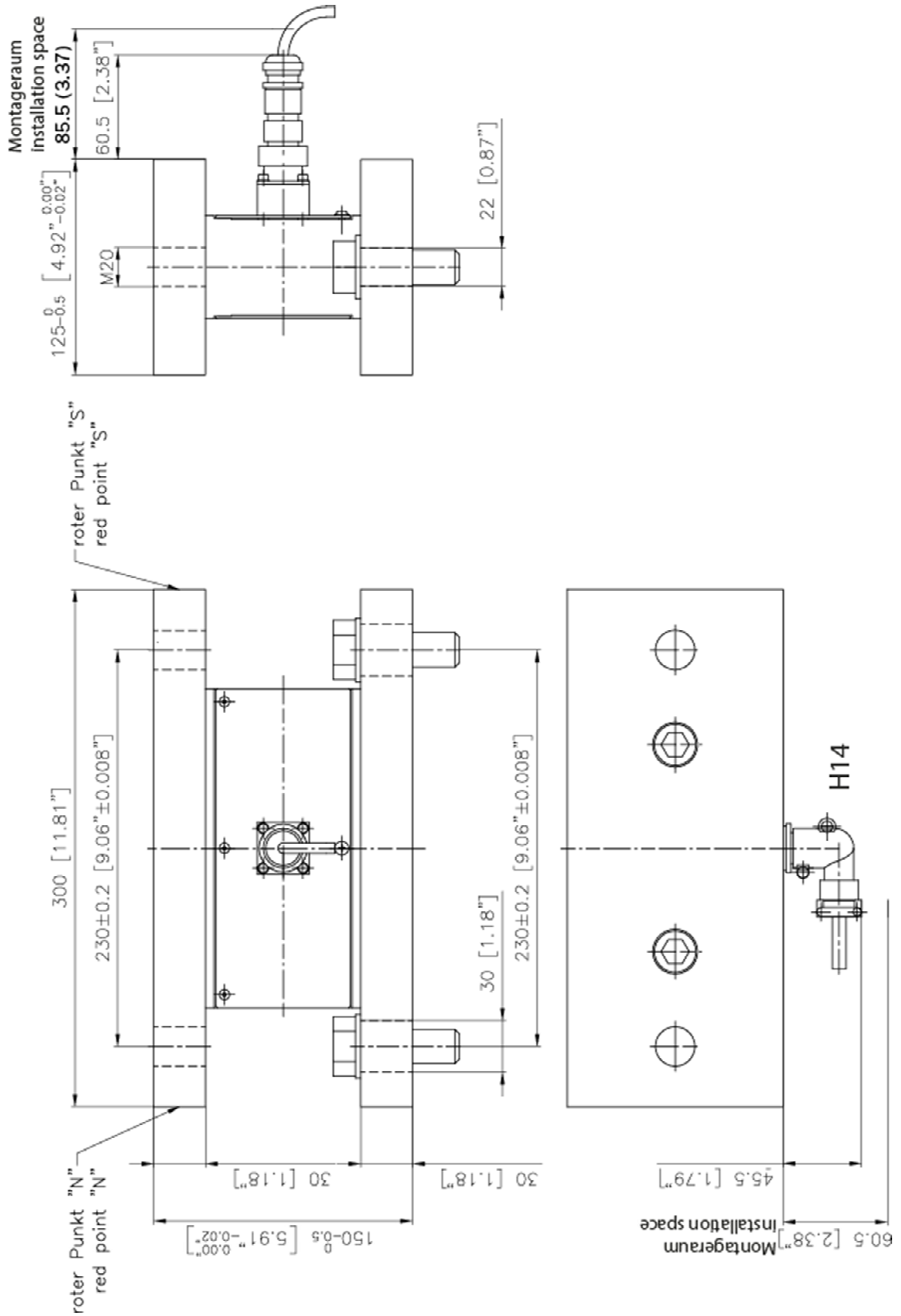

Illustration 5: Dimensions

UMGZP_BA_Manual.ai

UMGZP-Series : Nominal forces, Deflection, Weight						
Size Type	Nominal force		Deflection		Weight	
	N (lbf.)		mm (in.)		kg (lbs.)	
UMGZP080	1000	(225)	0.30	(0.0118)	23	(50)
	2000	(450)	0.30	(0.0118)	23	(50)
	3000	(674)	0.30	(0.0118)	23	(50)
	5000	(1124)	0.30	(0.0118)	23	(50)
	10000	(2248)	0.16	(0.0063)	23	(50)

Table 2: Dimension overview

Datasheet_UMGZP_series.indd



**FMS Force Measuring
Systems AG**
Aspstrasse 6
8154 Oberglatt (Switzerland)
Tel. 0041 1 852 80 80
Fax 0041 1 850 60 06
info@fms-technology.com
www.fms-technology.com

FMS USA, Inc.
2155 Stonington Avenue
Suite 119
Hoffman Estates,, IL 60169
(USA)
Tel. +1 847 519 4400
Fax +1 847 519 4401
fmsusa@fms-
technology.com

FMS (UK)
Aspstrasse 6
8154 Oberglatt (Switzerland)
Tel. +44 (0)1767 221 303
fmsuk@fms-technology.com

FMS (Italy)
Aspstrasse 6
8154 Oberglatt (Switzerland)
Tel. +39 02 39487035
fmsit@fms-technology.com