



## Installation Instruction PMGZ

Hermetically sealed measuring block for the paper industry

Document version 4.20

Issue date / Author 03/2021 NS



**Diese Montageanleitung ist auch in Deutsch erhältlich.**

**Bitte kontaktieren Sie Ihre FMS Vertretung.**

© by FMS Force Measuring Systems AG, CH-8154 Oberglatt – All rights reserved.

# 1 Table of contents

<b>1</b>	<b>TABLE OF CONTENTS .....</b>	<b>2</b>
<b>2</b>	<b>SAFETY INSTRUCTIONS.....</b>	<b>3</b>
2.1	Presentation of safety information .....	3
2.1.1	Danger that could result in minor or moderate injuries.....	3
2.1.2	Note regarding proper function .....	3
2.2	General safety information .....	3
<b>3</b>	<b>PRODUCT INFORMATION.....</b>	<b>4</b>
3.1	Product description .....	4
3.2	Functional description .....	4
3.3	System arrangement.....	4
3.3.1	Vertical measuring block.....	5
3.3.2	Horizontal measuring block .....	6
3.4	Scope of delivery.....	7
3.5	Order code .....	7
<b>4</b>	<b>INSTALLATION.....</b>	<b>8</b>
4.1	Installation conditions.....	8
4.2	Preparing the machine frame.....	8
4.3	Electrical connections .....	9
4.1	Sensitivity of 0.5 mV/V .....	9
<b>5</b>	<b>TECHNICAL DATA .....</b>	<b>10</b>
<b>6</b>	<b>DIMENSIONS IN MM (IN.) .....</b>	<b>11</b>

## 2 Safety instructions

All safety related regulations, local codes and instructions that appear in the manual or on equipment must be observed to ensure personal safety and to prevent damage to the equipment connected to it. If equipment is used in a manner not specified by the manufacturer, the protection provided by the equipment may be impaired.

Do not stress the equipment over the specification limits neither during assembly nor operation. To do so can be potentially harmful to persons or equipment in the event of a fault to the equipment.

### 2.1 Presentation of safety information

The following safety symbols appear in this manual.

#### 2.1.1 Danger that could result in minor or moderate injuries



Danger, warning, caution

Failure to follow wiring instructions in this manual may result in equipment damage or personal injury.

#### 2.1.2 Note regarding proper function



Note

Note regarding proper operation  
Simplification of operation  
Ensuring function

### 2.2 General safety information



The force sensors may not be stressed over the specification limits neither during assembly nor operation. The unit's overload protection value may not be exceeded.



The attachment points for the force sensors on the machine frame must be properly designed. The pillow blocks need to be appropriately mounted.

## 3 Product information

### 3.1 Product description

The force sensors of the PMGZ-Series, designed for the measurement of strip tension on continuous paper processing lines, are used in combination with standard pillow blocks. This feature allows for easy maintenance or exchange of the blocks, bearings and roll. Block mounting is simple utilizing four fasteners into the bottom surface and mounting holes for the pillow block bearing are included based on your specifications. In addition, the 6 m cable allows for an electrical connection away from the harsh environment. The PMGZ-Series is available in two measuring, horizontal and vertical, and thus can be specified for use in any mounting orientation and strip wrap configuration. With the superior performance of the PMGZ-Series, accurate tension readings are obtained even with low web wrap angles and high roll weights.

### 3.2 Functional description

The PMGZ-Series design, incorporating dual bending beams, eliminates the load-specific influences of torque. The movement of the bending beams is detected by a set of strain gages arranged in a full bridge circuit. The resulting electrical signal, which is proportional to the applied force, is then amplified for use in monitoring or controlling web tension. The red point located on the sensor body indicates the positive measuring direction, and the substantial overload protection (10-times nominal force) translates to eliminated / minimized calibration issues due to machine upset conditions. The hermetically sealed sensor cover will provide protection for the measuring electronics inside the sensor body from dirt, etc.

### 3.3 System arrangement

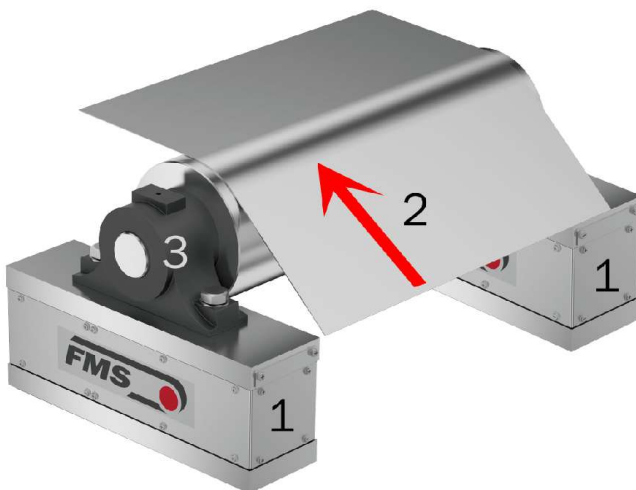
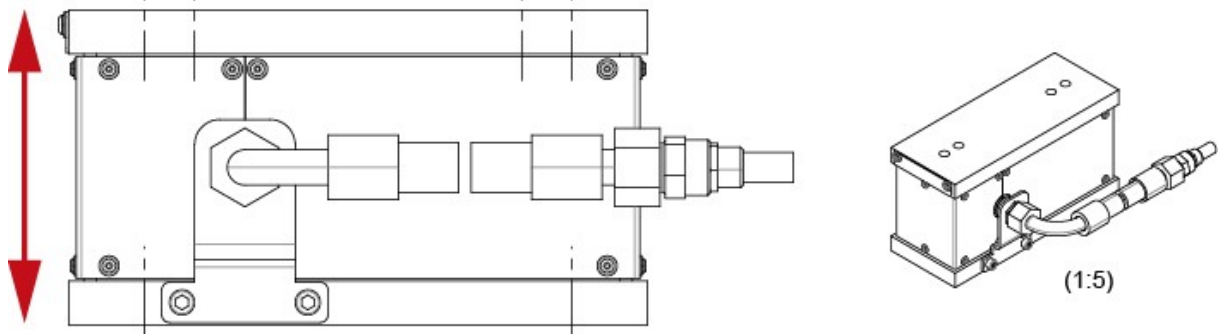

*Illustration 1: arrangement of force sensors*      *smgz\_mit\_walze\_und\_blech.tif*

System arrangement	
Position	Description
1	Force sensors (electrical connections are not displayed)

2	Strip with moving direction
3	Left pillow block with shaft and roller

### 3.3.1 Vertical measuring block



Vertikaler Messblock - kein roter Punkt  
vertical measuring block - no red point

Illustration 2: Side view of vertical version with measuring direction  
SMGZ\_PMGZ\_BA\_Manual.ai

FMS recommends the use of the vertical version only for compressive loads.

If the forces act with angles deviating from the vertical in the case of version V, only a reduced force can be measured by the force measuring block according to the correction table. This must be taken into account when determining the amplification factor. The angle should not exceed 30°.

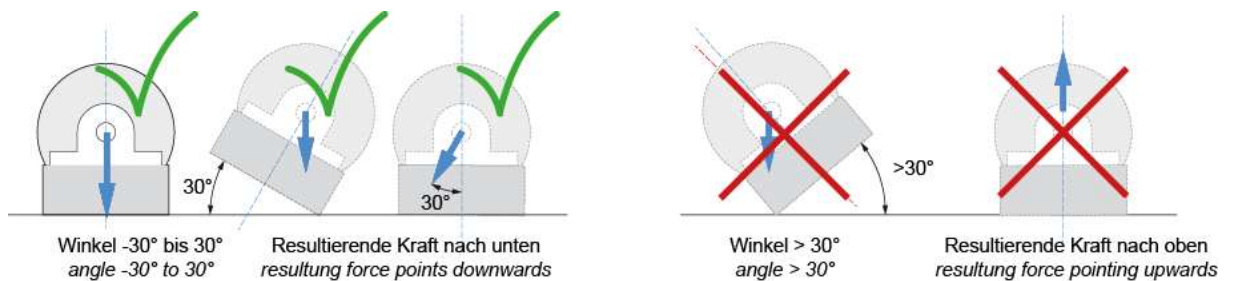

Illustration 3: Angular deviation, tensile stress

UMGZ\_BA\_Manual.ai

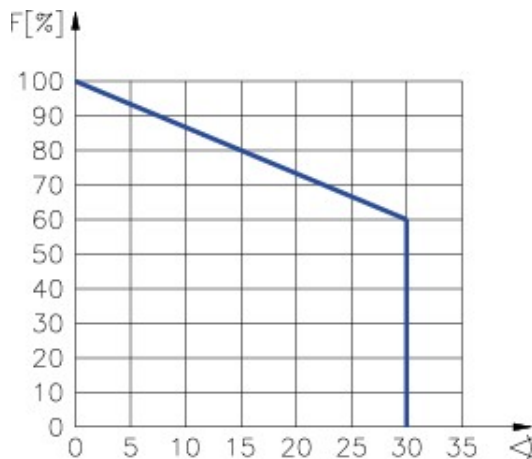
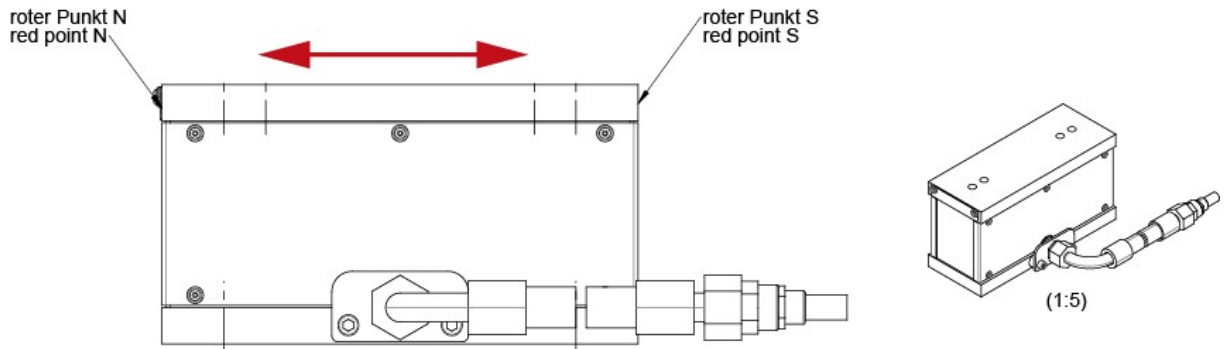

Illustration 4: angle correction table

UMGZ\_BA\_Manual.ai

### 3.3.2 Horizontal measuring block



Horizontaler Messblock - Orientierung roter Punkt in Abhängigkeit von elektrischem Anschluss  
 horizontal measuring block - red point orientation depending on electrical connection

**Illustration 5: Side view of horizontal version with measuring direction**  
 SMGZ\_PMGZ\_BA\_Manual.ai

### 3.4 Scope of delivery

**Included:**

straight electrical connection, 6 m (19.7 ft.) cable, 5 m (16.4 ft.) cable protection hose, other lengths on request, the sealing of the open end of the cable is provided with a threaded connection M16 x 1.5mm (female thread required)

**Options**

H26 right-angled electrical connection

**Accessories**

None

### 3.5 Order code

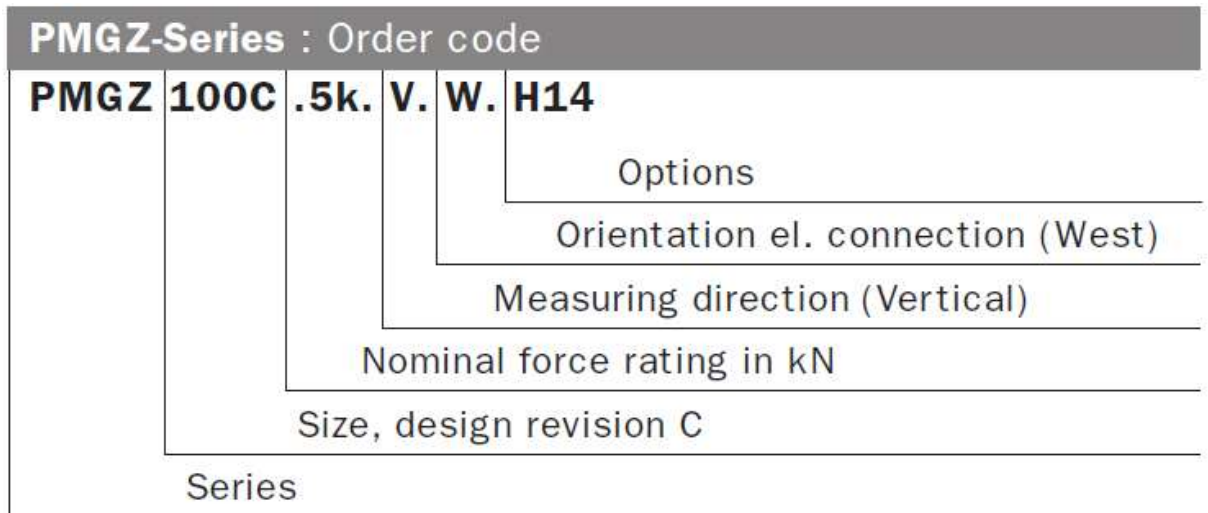

Illustration 6: Ordering code

Datasheet\_PMGZ\_series.indd

## 4 Installation

### 4.1 Installation conditions

Force sensors are defined as “partly completed machinery” according to the Directives 2006/42/EC, article 2. In order to assure a proper functionality of the parts and assure the essential safety requirements of operators working with it, the following conditions for the assembly must be met:



The Force Measuring Rollers may not be stressed over the specification limits neither during assembly nor operation. The unit's overload protection value may not be exceeded.



The mounting points for the Force Measuring Rollers on the machine frame must be properly designed. The bearings need to be appropriately mounted.



For proper installation and operation, follow the electrical wiring diagram and instructions in this manual.

### 4.2 Preparing the machine frame

Two force sensors are required to equip a measuring roller. For the installation of each block an even surface with the respective bore pattern needs to be prepared on the machine frame.

The contact surfaces for both force sensors must be even and aligned in the same height to ensure proper alignment of the measuring roller.

#### **Vertical measuring blocks:**

These version measures forces in vertical direction. Compressive force leads to a positive, tensile forces should be avoided. **Vertical measuring blocks do not have a Red Point.**

#### **Horizontal measuring blocks:**

The Red Point indicated the direction where a applied force will generate a positive signal.

The design will allow the easy installation of a pillow block. With a customized adapter plate the force sensor will be able to hold any other type of roller supports.

The roller support needs to be realized with fixed and a floating bearing side.



### 4.3 Electrical connections

Connection between the force sensors and the amplifier is realized by means of a 4-pole cable with a cross-section of 0.25mm<sup>2</sup>. The cable must be installed separate from power lines.

The shield needs to be connected to the amplifier only.

The single wires are labeled with numbers.

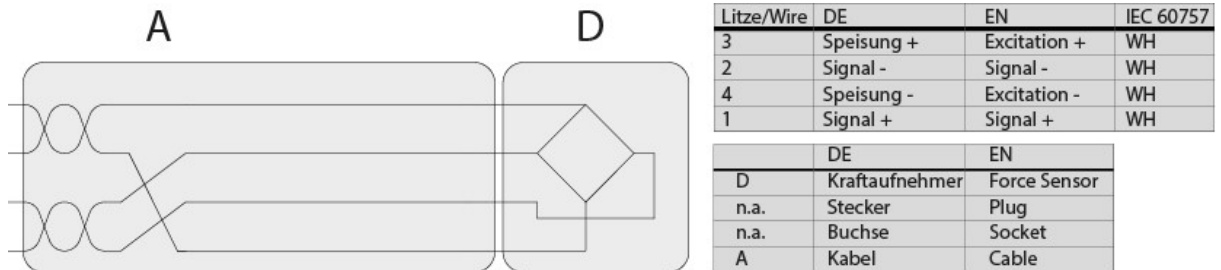

*Illustration 7: electrical connection*  
*Pin\_Assignment\_Sensorkabel\_Farben\_Stecker.ai*

### 4.1 Sensitivity of 0.5 mV/V



#### Special measuring amplifiers

With these force sensors, FMS recommends the combination with measuring amplifiers with the option V05

If you are using a regular measuring amplifier without option V05:



#### Scaling of measuring signal, gain factor

Especially for small wrap angles you should increase the parameter "system force" in the measuring amplifier by factor 3.6.

This will provide a significantly improved output signal.

#### Example

You are using two forces measuring blocks with 3000 N nominal force each. This results in a system force of 2 x 3000 N = 6000 N.

WE recommend to adjust the system force to 3.6 x 6000 = 21600 N

## 5 Technical data

Sensitivity	0.5 V/mV
Tolerance of the sensitivity	<± 0.2 %
Accuracy class	±0.5% of the nominal force
Temperature coefficient	±0.1%/10K
Temperature range	-10 to +120 °C (14 to 248 F)
Input resistance	350Ω
Excitation voltage	1 to 10VDC
Overload protection	10-time the nominal force
Material sensor body	Stainless steel
Protection rating	IP67
Electrical connection	PG gland with 6 m cable (VG 95218), other lengths on request
Repeatability error	0.05%
Measuring range	30:1

*Table 1: Technical data*

## 6 Dimensions in mm (in.)

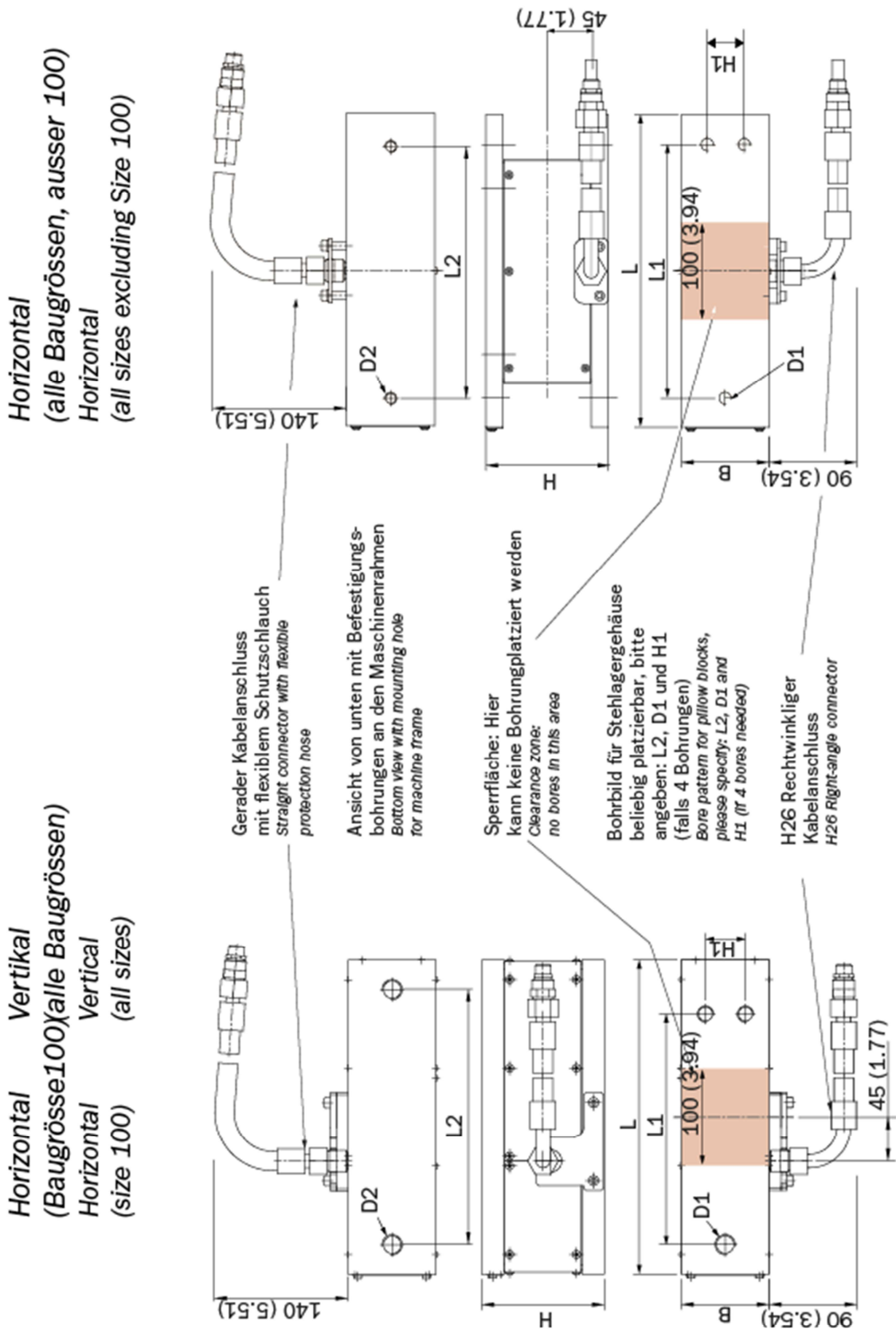

Illustration 8: Dimensions of vertical version

SMGZ\_PMGZ\_BA\_Manual.ai

PMGZ-Series : Shaft diameter, Nominal forces				
Size Type	Shaft diameter mm (in.)		Nominal force kN (lbf.)	
PMGZ100C	20/50	(0.79/1.97)	1 000, 2000, 5000, 10kN, 20kN (225, 450, 1124, 2248, 4496)	
PMGZ200C	40/85	(1.57/3.35)	1000, 2000, 5000, 10kN, 20kN (225, 450, 1124, 2248, 4496)	
PMGZ300C	75/100	(2.95/3.94)	5000, 10kN, 20kN, 30kN (1124, 2248, 4496, 6744)	
PMGZ400C	85/120	(3.35/4.72)	10kN, 20kN, 40kN, 60kN, 80kN (2248, 4496, 11014, 13489, 17985)	
PMGZ500C	110/160	(4.33/6.30)	10kN, 20kN, 40kN, 60kN, 80kN (2248, 4496, 11014, 13489, 17985)	

PMGZ-Series : Dimensions, Installation bores					
Size Type	Dimensions mm (in.)			Installation bores bottom L 2 x D 2 mm (in.)	
	L	B	H		
PMGZ100C	230 (9.06)	90 (3.54)	125 (4.92)	170 x M16	(6.69 x M16)
PMGZ200C	320 (12.60)	90 (3.54)	125 (4.92)	260 x M20	(10.24 x M20)
PMGZ300C	380 (14.96)	110 (4.33)	125 (4.92)	320 x M24	(12.60 x M24)
PMGZ400C	450 (17.72)	130 (5.12)	125 (4.92)	390 x M24	(15.35 x M24)
PMGZ500C	560 (22.05)	170 (6.69)	150 (5.91)	470 x M30	(18.50 x M30)

Table 2: Dimension overview

Datasheet\_PMGZ\_series.indd



**FMS Force Measuring Systems AG**  
 Aspstrasse 6  
 8154 Oberglatt (Switzerland)  
 Tel. 0041 1 852 80 80  
 Fax 0041 1 850 60 06  
 info@fms-technology.com  
 www.fms-technology.com

**FMS USA, Inc.**  
 2155 Stonington Avenue  
 Suite 119  
 Hoffman Estates,, IL 60169  
 (USA)  
 Tel. +1 847 519 4400  
 Fax +1 847 519 4401  
 fmsusa@fms-technology.com

**FMS (UK)**  
 Aspstrasse 6  
 8154 Oberglatt (Switzerland)  
 Tel. +44 (0)1767 221 303  
 fmsuk@fms-technology.com

**FMS (Italy)**  
 Aspstrasse 6  
 8154 Oberglatt (Switzerland)  
 Tel. +39 02 39487035  
 fmsit@fms-technology.com

