

FMS Belt Scales / Electronics Unit

BMGZ750.PNET-Series Calibratable electronics for belt scales with PROFINET RT interface

- **Robust design, IP65**
Heavy aluminium housing with resistant display and controls
- **Intuitive operation and configuration, best visibility**
Graphical display, auto tare function, calibration via integrated calculation
- **Simple configuration**
Integrated web browser
- **Simple system integration via ethernet**
Integrated PROFINET RT interface
- **Basis for direct billing to customers**
Calibratable version



BMGZ750.PNET-Series

The electronics of the BMGZ750-series has been designed for the demanding applications of mobile and stationary conveying systems. The illuminated, graphical display indicates the actual performance, daily amount, total amount and belt speed. Configurable analog and digital outputs are available to connect additional displays or controllers. All data is also provided via the integrated PROFINET RT interface for easy system integration and data management. The factory-provided integrated web browser allows for quick configuration of the electronics via a regular laptop or pc and can even grant remote access to the system.

Functional description

The electronics of the BMGZ750-series converts and digitalizes the signals of the measuring roller. The electronics subtracts the weight of the measuring roller and the belt (tare) from the actual reading and multiplies the result with the belt speed. The BMGZ750-series features an auto tare function which allows automatic evaluation of the tare value during two turns of the belt.

BMGZ750.PNET.W Wall mount housing (IP65) : Dimensions mm (in.)

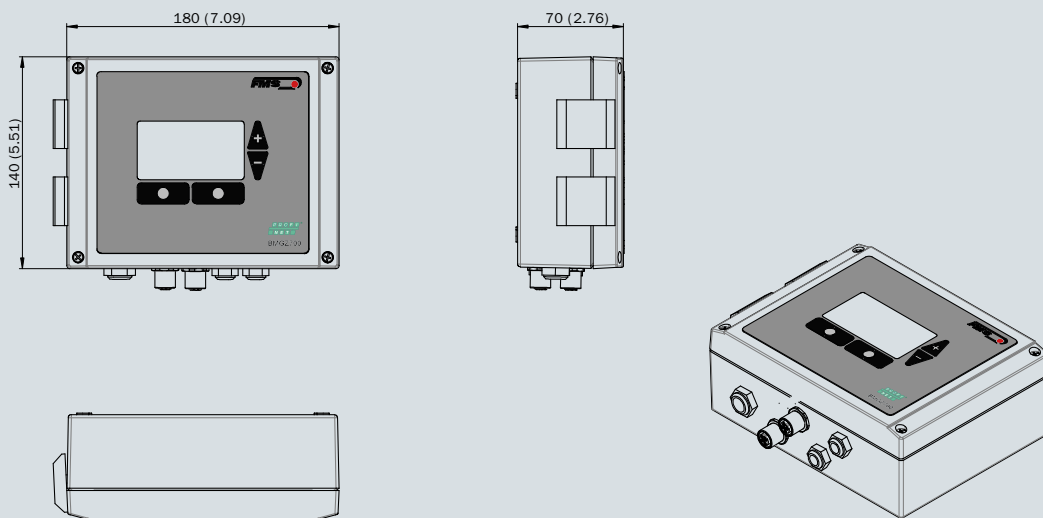

BMGZ750.PNET.S for panel mount (IP65 when installed) : Dimensions mm (in.)

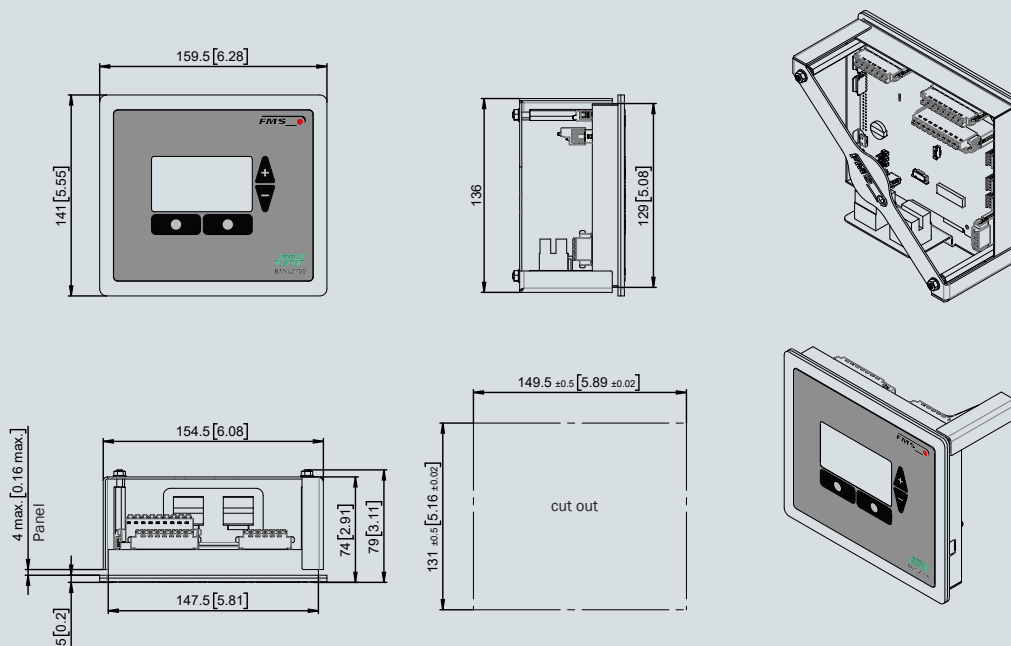

BMGZ750.PNET.K Integrated in steel cabinet (IP65) : Dimensions mm (in.)

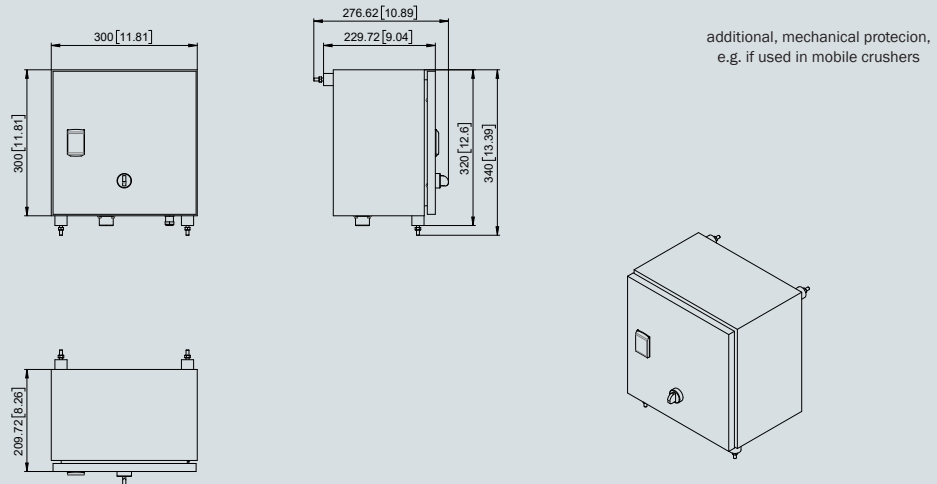

BMGZ750.PNET : Technical data

| | |
|------------------------------------|--|
| Accuracy class electronics | 0.05 % |
| Number of channels | 1, for one measuring roller |
| Displayed values | total amount [t], daily amount or batch [t], actual performance [t/h], belt speed [m/s] as absolute value or histogram |
| Daily amount, batch counter | 0 to 1,000 t (resolution 5 kg); 1,000 to 10,000 t (resolution 10 kg); 10,000 to 100,000 t (resolution 100 kg); 100,000 to 1,000,000 t (resolution 1000 kg) |
| Operation and display | 4 buttons, graphical, illuminated 128 x 64 px STN LCD, alternatively via web browser |
| Total amount | 0 to 1 Mio. t (resolution 1000 kg) |
| Digital outputs | Tare active, 24 VDC, max. 100 mA; Belt scale o.k., 24 VDC, max. 100 mA; Remote counter, impulse 1 to 1000 ms, 24 VDC, max. 100 mA; Reset remote counter, 24 VDC, max. 100 mA |
| Digital inputs | start tare procedure, production batch active, speed probe |
| Analogue output | Current output: 0/4 to 20 mA, min. 500 Ω or power output: 1 to 10 VDC, min. 1000 Ω |
| Cycle time | 1 ms |
| Temperature range | -10 to +50 °C (14 to 122 F) |
| Power supply | 24 (18 to 36) VDC |
| Power consumption | 5 W |
| Weight | 1.5 kg (2.2 lbs.) |
| Ethernet interface | Profinet RT |

BMGZ750.PNET : PROFINET Features

| | |
|----------------------------------|--|
| Cycle time | 1 ms for RT_CLASS_3, 1 ms for RT_CLASS_1 |
| Media redundancy | Media Redundancy Protocol (MRP) – Client |
| IRT Support | Yes, RT_CLASS_3, synchronous with network clock |
| Integrated Switch | 2 Port |
| PROFINET IO specification | V 2.3, legacy startup of specification V 2.2 is supported |
| Certification | PNIO version V 2.35, net load class: CLASS III, conformance class (CC-C) |

BMGZ750.PNET : Order code

BMGZ7 5 0 .W .PNET

- Profinet RT ethernet interface
- Housing (.W wall mount; .S. panel mount; K. in cabinet)
- Additional functionality (none)
- Variation (1: Single-channel; 5: calibratable)
- Series

BMGZ750.PNET : Scope of supply

- electronics unit
- 15 m (49 ft) connecting cable to measuring roll (other lengths on request)
- measuring roll (separate order code)

BMGZ710.PNET : Typical application



Other products : Construction and recycling

BMGZ041 Troughed measuring roll



BMGZ021 Flat measuring roll



About FMS

FMS Force Measuring Systems AG is the market leader in the field of web tension measurement, control and specialist for web guiding solutions. For the wire industry we are the only manufacturer offering a complete range of technologies for force measurement, data processing and radio transmission of signals.

Our in house developed products are used in the manufacturing industry, converting, metals, paper, textiles, as well as in cable and wire rope production. Utilising the latest technology, high quality components and a firm understanding of customer applications, FMS supports customers worldwide in the effort to maximize the productivity of their machines. Since 1993, our highly qualified employees have been creating high-end solutions for machine builders and plant operators. As an owner-managed company, we pride ourselves on being personal and approachable with the ability to make decisive moves fast. FMS also very successfully develops and produces robust belt scales for all kinds of bulk materials.

World Headquarters: FMS Force Measuring Systems AG

Aspstrasse 6 • 8154 Oberglatt (Switzerland) • Phone + 41 44 852 80 80 • Fax + 41 44 850 60 06
 info@fms-technology.com • www.fms-technology.com