



Operating Instructions

EMGZ491.ECAT

Single-channel measuring amplifier for EtherCAT®

EMGZ491.R.ECAT for mounting on DIN rail

EMGZ491.W.ECAT for wall mounting

Document Version	1.4, 01/2021 NS
Firmware Version	V 2.0.4
ESI File	FMS_TensionAmplifier_EMGZ49X.xml



Diese Bedienungsanleitung ist auch in Deutsch erhältlich.

Bitte kontaktieren Sie Ihre lokale FMS Vertretung.

EtherCAT® is a registered trademark and patented technology, licensed by Beckhoff Automation

© by FMS Force Measuring Systems AG, CH-8154 Oberglatt – All rights reserved.
GmbH, Germany.

1 Table of Contents

1	TABLE OF CONTENTS	2
2	SAFETY INFORMATION	3
2.1	Presentation of Safety Information.....	3
2.1.1	Danger that Could Result in Minor or Moderate Injuries	3
2.1.2	Note Regarding Proper Function	3
2.2	General Safety Information	4
3	PRODUCT DESCRIPTION	5
3.1	Block Diagram.....	5
3.2	System Description	5
3.3	Scope of Delivery	5
4	QUICK GUIDE/QUICK START	6
4.1	Preparations for Parameterization	6
4.2	Mounting Sequence	6
4.3	Mounting and Electrical Connections.....	6
4.4	Load Cell Mounting	7
4.5	Electrical Connections.....	7
4.5.1	EMGZ491.R.ECAT	7
4.5.2	EMGZ491.W.ECAT	8
4.5.3	Ethernet Connections	9
5	CALIBRATION OF THE MEASURING SYSTEM.....	10
5.1	Offset Compensation	10
5.2	Calibration in the Amplifier (Adjusting the Gain Factor).....	10
5.3	Calibrating	10
5.4	Gain.....	11
5.5	Limit Value Violations.....	12
5.5.1	Overload Test	12
5.5.2	Overflow and Underflow Test	12
5.6	Description of the LEDs	13
6	INTEGRATION INTO THE ETHERCAT® NETWORK.....	14
6.1	EtherCAT® Interface.....	14
6.2	System Start.....	14
6.3	Data Exchange.....	14
7	CONFIGURATION.....	15
7.1	Parameter Description	15
7.2	Cyclic Data Traffic	18
7.3	Acyclic Data Traffic	20
8	ETHERCAT® COMMUNICATION	24
8.1	Services and Protocols	24
9	DIMENSIONS	25
10	TECHNICAL DATA.....	26

2 Safety Information

All safety information, operating and installation regulations listed here ensure proper function of the device. Safe operation of the systems requires compliance at all times. Noncompliance with the safety information or using the device outside of the specified performance data can endanger the safety and health of persons.

Work with respect to operation, maintenance, retrofit, repair, or setting the device described here must only be performed by expert personnel.

2.1 Presentation of Safety Information

2.1.1 Danger that Could Result in Minor or Moderate Injuries



Danger, warning, caution

Type of danger and its source

Possible consequences of nonobservance

Measure for danger prevention

2.1.2 Note Regarding Proper Function



Note

Note regarding proper operation

Simplification of operation

Ensuring function

2.2 General Safety Information



The function of the measuring amplifier is only ensured with the components in the specified layout to one another. Otherwise, severe malfunctions may occur. Thus, observe the mounting information on the following pages.



Observe the local installation regulations.



Improper handling of the electronics module can lead to damage to the sensitive electronics!

Do not work with a blunt tool (screw driver, pliers, etc.) on the housing!

Use suitable grounding (grounding wrist strap, etc.) when working on the electronics.



The devices should have a distance of at least 15 mm to one another in the control cabinet for proper cooling.

3 Product Description

3.1 Block Diagram

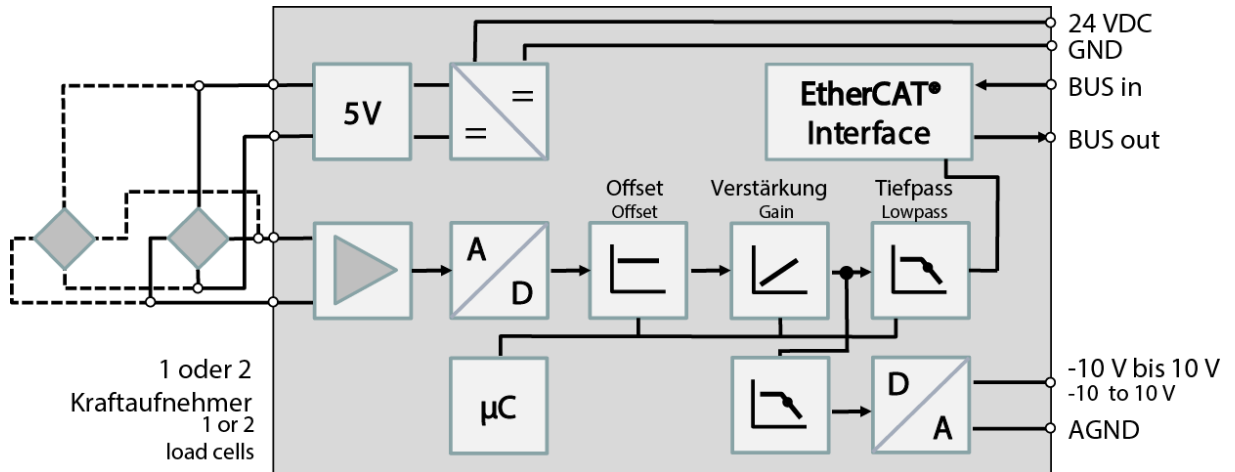

Figure 1: EMGZ491.ECAT block diagram

3.2 System Description

The microprocessor-controlled measuring amplifier EMGZ491.ECAT series is used in processing, amplifying, and relaying sensor signals in suitable form to downstream devices. The measured force values are available via EtherCAT® and an analog voltage output.

The measuring amplifiers are suitable for tension measurements using all FMS load cells. 1 or 2 sensors can be connected to the device.

3.3 Scope of Delivery

The following is included in the scope of delivery

- Measuring amplifier
- Mounting and operating instructions

The following is not included in the scope of delivery

- AC/DC power supply, minimum requirement: EMC immunity specifications EN61000-4-2, 3, 4, 5; EN55024 light industry level, criteria A, e.g., TRAKO TXL 035-0524D
- Cable for power supply

The following is not included in the scope of delivery, but are available as accessories from FMS

- Patch cable with RJ45 plug (straight or 90°)
- Sensor cable for the connection of load cell and measuring amplifier
- M12 plug, D-coded

4 Quick Guide/Quick Start

In these operating instructions, commissioning of the EMGZ491.ECAT amplifier is limited to the installation procedure, offset compensation, and system calibration.

4.1 Preparations for Parameterization

- Read the operating instructions of the selected load cell carefully.
- Check your requirements on the system, such as:
 - o Used units in the system
 - o Used outputs (- 100 to 10 V and bus)
- Filter settings for actual force value and analog output
- Create the connection diagram for your specific system layout (see chapter "Electrical Connection")

4.2 Mounting Sequence

- Mount the load cells (mounting details can be obtained from the mounting instructions of the load cells)
- Connect the load cells to the amplifier (see 4.5)
- Connect the amplifier to the supply voltage. The voltage supply must be in the range of 18 to 36 VDC. (See 4.5)
- Perform offset compensation and calibration (see 5.1 and 5.3)
- Change the parameter settings as needed (see 7)
- Amplifier integration into the EtherCAT® network (see 8)

4.3 Mounting and Electrical Connections



Warning

To improve natural convection and keep heating of the amplifiers as low as possible, the devices installed in a cabinet should have a minimum distance of 15 mm.



Warning

The function of the measuring amplifier is only ensured with the components in the specified layout to one another. Otherwise, severe malfunctions may occur. Thus, the mounting information on the following pages must be followed



Warning

The local installation regulations ensure the safety of electrical systems. They are not considered in these operating instructions. However, they must be met.

4.4 Load Cell Mounting

The load cells are mounted in line with the mounting instructions of the respective products. The mounting instructions are included with the load cells.

4.5 Electrical Connections

One or two load cells can be connected to the EMGZ491.ECAT. When two sensors are used, they are connected in parallel internally. The load cells and amplifier are connected using a 2x2x0.25 mm² [AWG 23] shielded, twisted cable.

4.5.1 EMGZ491.R.ECAT

Spannungsversorg.		Kraftaufnehmer 1		Kraftaufnehmer 2		Analogausgang	
1	24 VDC	5	+ Speisung	9	- Speisung	13	± 10 V
2	GND	6	+ Signal	10	- Signal	14	GND
3	PE	7	- Signal	11	+ Signal	15	n.a.
4	Schirmung	8	- Speisung	12	+ Speisung	16	Schirmung

Power Supply		Load Cell 1		Load Cell 2		Analog Output	
1	24 VDC	5	+ Excitation	9	- Excitation	13	± 10 V
2	GND	6	+ Signal	10	- Signal	14	GND
3	PE	7	- Signal	11	+ Signal	15	n.a.
4	Shield	8	- Excitation	12	+ Excitation	16	Shield

Figure 2: EMGZ491.R.ECAT electrical connections

For easier installation, the terminal blocks can be detached from the main housing.



Figure 3: Detachable terminal blocks: use a small slotted screwdriver as a lever

4.5.2 EMGZ491.W.ECAT

The 4 screws of the cover with the PG glands and the M12 plug must be loosened for board access. You can slide out the board by approx. 2 cm (1 in.) and loosen the terminal blocks for easier connection of the wires.

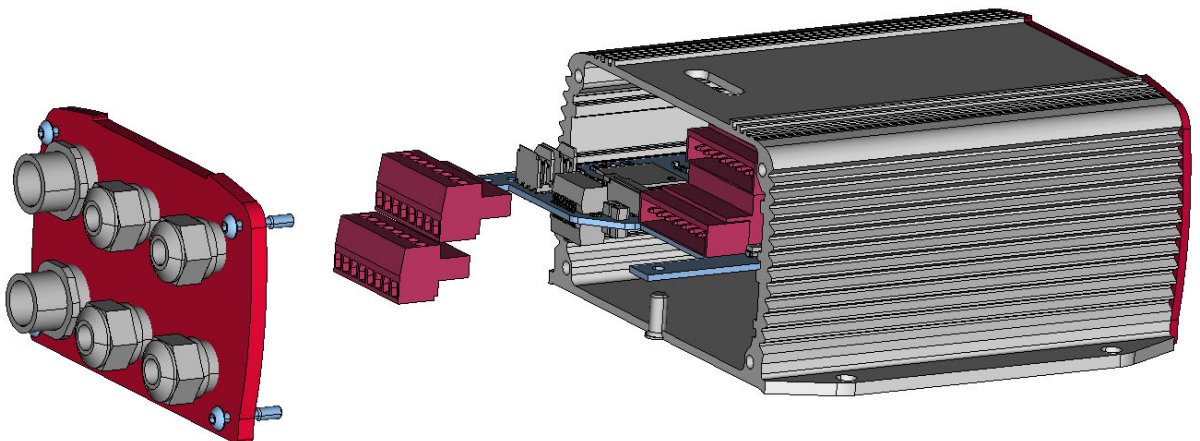

Figure 4: Pc board with removable terminal blocks EMGZ491_W_PNET_16-11.30.FCStd

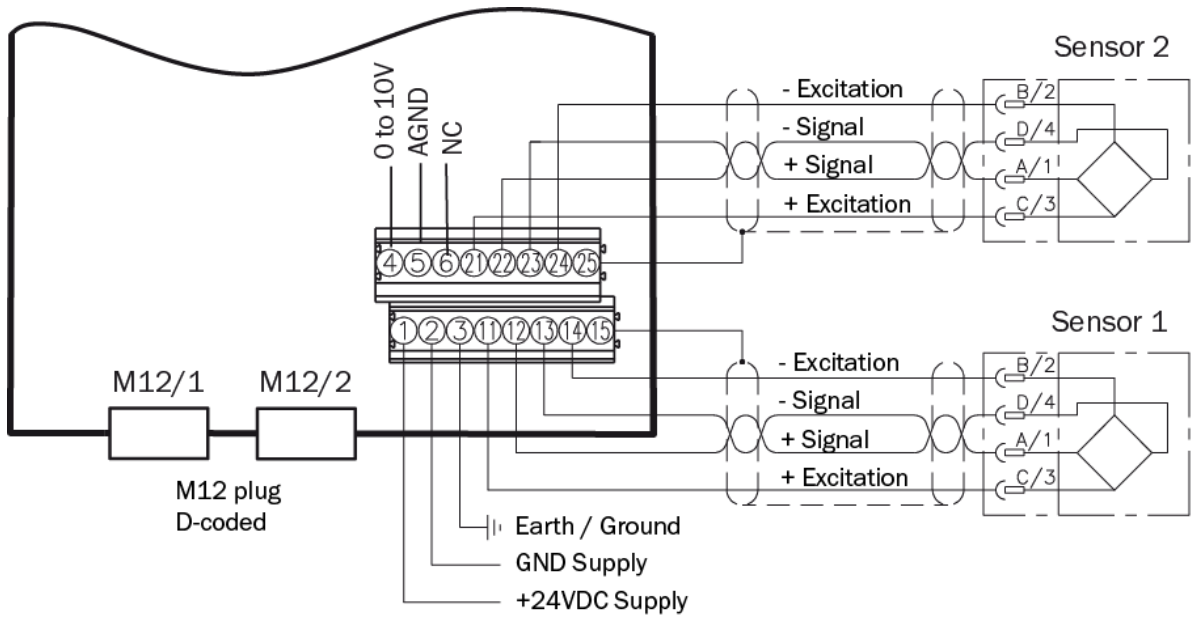

Figure 5: EMGZ491.W.ECAT electrical connections EMGZ491_ECAT_Grafik.ai

4.5.3 Ethernet Connections

Signal	Name	EtherCAT®	EIA T568B	Pin RJ45	Pin M12
TD+	Transmission Data +	YE	WH/OG	1	1
TD-	Transmission Data -	OG	OG	2	3
RD+	Receive Data +	WH	WH/GN	3	2
RD-	Receive Data -	BU	GN	6	4

Table 1: pin assignment Ethernet connection EMGZ491_ECAT_Grafik.ai



Poor grounding can result in electric shocks for persons, malfunctions of the overall system or damage to the measuring amplifier! Proper grounding must always be ensured.



Note

Cable shielding may only be connected to one side of the measuring amplifier. On the side of the load cell, shielding must remain open.

5 Calibration of the Measuring System

5.1 Offset Compensation

Using offset calibration, the weight of the measuring roller and the roller bearings is compensated and the measuring system “zeroed”.

Offset compensation must always be executed prior to the actual calibration. The measuring roller must not be loaded during the procedure.

To change the values for the offset compensation, please refer to 7.3.

5.2 Calibration in the Amplifier (Adjusting the Gain Factor)

Calibration is used for matching the gain factor with the load cells. After calibration, the displayed force corresponds to the force effectively affecting the material. Two calibration methods are available. The first calibration method described here uses a defined weight. There is also a calculation method for the gain. The weight-based calibration method is simple and delivers more accurate results as it replicates the material profile (see the figure below) and considers the actual circumstances in the machine.

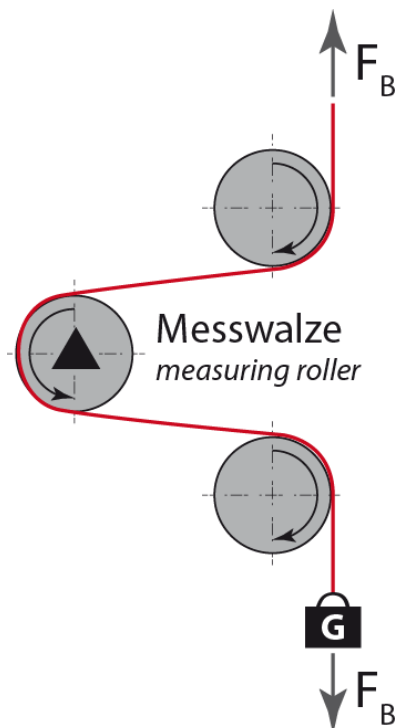

Figure 6: Replication of the material profile using a defined weight
Tension_Control_Solutions.ai

5.3 Calibrating

To change the values for the calibration, please refer to 7.3.

- Connect the first load cell (see 4.5).
- The measuring signal must become positive for loads in measuring direction. If it is negative, the signal lines of the affected load cells must be switched at the terminal block (see 4.5).
- If available, connect the second load cell.
- The measuring signal must become positive for loads in measuring direction. If it is negative, the signal lines of the affected load cells must be switched at the terminal block (see 4.5).
- Insert material or rope into the machine, without weight/load.
- Perform offset compensation
- Load material or rope with a defined weight (see 5.2).
- Perform calibration

5.4 Gain

Depending on the material wound around the measuring roller, the applied force is not relayed to the sensors 1:1. Thus, the measured force does not correspond to the effectively applied force. To correct for this error, the measured force is amplified using a factor. The factor that is referred to as gain or gain factor is calculated such that the resulting force corresponds to the applied force. The gain is calculated per the following formula:

$$\text{Gain} = \frac{F_{\text{sys Digit}} * F_{\text{act N}}}{F_{\text{sys N}} * F_{\text{act Digit}}}$$



Option V05

The standard version uses a sensor feedback signal of ± 9 mV. Measuring amplifiers with the option V05 are designed for a sensor feedback signal of ± 2.5 mV. The other values in the following description are identical.

Explanations	
Variable	Description
$F_{\text{sys Digit}}$	Is the system force as binary value after the A/D converter. This value is a constant with value 11'890. It is independent from the number of used load cells. From the user's point of view, this value corresponds to an input signal of 9 mV. The amplifier can measure up to an overload of 37 %.
$F_{\text{act N}}$	Effectively applied force at the measuring system in Newtons.
$F_{\text{sys N}}$	Is the system force of the measuring system in Newtons. It is determined by the number of used load cells. For one load cell, the system force equals the nominal force of the load cell. For two sensors, it is twice as high.

F_{act} Digit	Measured force at the measuring system as binary value after the A/D converter. From the user's point of view, this value corresponds to a voltage in mV, which is relayed by the measuring system to the amplifier.
------------------------------	----------------------------------------------------------------------------------------------------------------------------------------------------------------------------------------------------------------------

Example

- System force at 9 mV = 11'890 digit
- 2 load cells with 500 N nominal force each, as per type plate; F_{sys} N = 2 x 500 N = 1'000 N;
- Use of a defined weight of 50 kg (corresponds to approx. 500 N); F_{act} N = 500 N
- Obtain measured force with suspended weight from the PLC, e.g., F_{act} Digit = 4'980

$\text{Gain} = \frac{11'890 * 500\text{N}}{1'000\text{N} * 4'980} \text{V} = 1.194$

5.5 Limit Value Violations

The amplifier checks the analog input and output for limit value violations. At the input, it is checked using the input voltage, whether the load cell is mechanically overloaded (overload test). The measuring amplifier can measure an overload of 37 %. At the output, it is checked, whether the output voltage depending on the amplified input signal will be above or below the physically possible value. In this case, an overflow and/or underflow is present.

5.5.1 Overload Test

The overload test is performed using the raw value read on the ADC. It has thus not related to any force and can be applied independently from the system force to every load cell.

Test rule:

The FMS load cells deliver 9 mV at the output under nominal force load. In the case of a load up to the mechanical stop, approx. 12.4 mV are output. These values apply, if the load cell is loaded in normal operating direction (red point). In reverse direction, the values are respectively negative. The amplifier checks overload in both directions.

The limit value for overload is fixed set to 12 mV and/or -12 mV. If one of these limit values is reached, the overload status bit is set. The bit is removed again, as soon as the raw value is 0.5 mV below and/or above the triggering limit value.

5.5.2 Overflow and Underflow Test

The overflow and underflow test is performed with the output value that is relayed to the DAC, calculated from the gain. If the output value exceeds the maximum possible value, an overflow is present. If it undercuts the minimum possible value, an underflow is present.

Test rule

The output voltage is between 0 and +10 V. A hysteresis of +/-10 digits is used for the test so that the error bits do not trigger for every small over- and/or underflow. Thus, the overflow triggers, when the theoretically calculated output value of 10.05 V is reached. For underflow, the value is 0.05 V. When these limit values are reached, the respective bits are set in the status. The bits are removed, as soon as the output value is within the valid range again (above 0.05 V and below 9,95 V).

5.6 Description of the LEDs

	LED	Meaning
	L/A IN	Off: no connection to the preceding EtherCAT module On: LINK: connection to the preceding EtherCAT module Flashing: ACT: Communication with the preceding EtherCAT module
	L/A OUT	Off: no connection to the following EtherCAT module On: LINK: connection to the following EtherCAT module Flashing: ACT: Communication with the following EtherCAT module
	RUN	Off: Status of the EtherCAT module is Init Flashes quickly: Status of the EtherCAT module is pre-operational Flashes slowly: Status of the EtherCAT module is safe-operational On: Status of the EtherCAT module is operational
EMGZ491.R.ECAT	ERR	Illuminates in red if no RJ45 plug is connected. Flashes red if communication with the PLC is interrupted.
EMGZ491.W.ECAT	RDY	Illuminates in green as soon as the voltage supply is connected and the processor is started.

Figure 7: Signal LEDs on EMGZ491.ECAT EMGZ491_ECAT_Grafik.ai

6 Integration into the EtherCAT® Network

The measuring amplifiers of the EMGZ491.ECAT series can operate in an EtherCAT® network. Here, the amplifier operates as EtherCAT® slave with an EtherCAT® master (e.g. TwinCAT).

6.1 EtherCAT® Interface

EtherCAT® is supported. The respective communication profile is selected by the EtherCAT® master via the ESI. The EMGZ491.ECAT transfers the actual value in digit and the status/error byte. In addition, parameters, such as offset actual value, gain actual value, filter actual value, filter analog output, as well as scaling analog output can be adjusted.

6.2 System Start

Module parameters are not supported.

6.3 Data Exchange

The EMGZ491.ECAT uses the communication types typical in EtherCAT®. Cyclic data traffic is used for the fast transmission of measured data. Acyclic data traffic is used for parameterization. Cyclic data traffic is used for transmitting the limit value violations.

7 Configuration

The EMGZ491.ECAT can be configured via EtherCAT®.

7.1 Parameter Description

Parameter	
Name	Description
Unit	<p>Here you select which unit of measurement is used. The label located on the sensor will indicate the nominal force in Newtons.</p> <p>Note:</p> <p>This input will also affect the unit of the cyclic process data.</p> <p>If lb (pound) is selected, the system switches from metric to imperial measuring units.</p> <p>Selection N, kN, lb, g, kg</p> <p>Specified value N</p>
Offset	<p>The values determined with the “Offset Compensation” procedure are stored in the form of a digital value in the [Offset] parameter. The value is used for compensating for the roller weight.</p> <p>Min. -16'000</p> <p>Max. 16'000</p> <p>Specified value 0</p>
Gain	<p>The gain factor ensures that the displayed force matches the effective force.</p> <p>Min. 0.100</p> <p>Max. 20.000</p> <p>Specified value 1.000</p>

<p>System force</p>	<p>The system force indicates which measuring force capacity is installed in the measuring roller. E.g., if two 500 N load cells are installed in the roller, 1'000 N must be entered. In the case of a one-sided measurement, hence is one 500 N load cell is used, 500 N must be entered. If force measuring rollers with pulleys are used (e.g., RMGZ series), the nominal force of the force measuring roller must be specified (in the example 500 N as well)</p> <p>Unit N</p> <p>Min. 1.00</p> <p>Max. 200'000.00</p> <p>Specified value 1'000.00</p>
<p>Low-pass filter active</p>	<p>Here, the status of the low-pass filter active value is indicated.</p> <p>Min. 0</p> <p>Max. 1</p> <p>Specified value 1</p> <p>0 = no, inactive, 1 = yes, active</p>
<p>Limit frequency low-pass filter actual value</p>	<p>The amplifier features a low-pass filter that filters the measured value, which is relayed via ETHERCAT® . This filter is used for suppressing undesired interference signals that are superimposed on the measuring signal. Using this parameter, the limit frequency of the filter is adjusted. The lower the limit frequency, the slower the measuring value.</p> <p>This low-pass filter is independent from the output filter.</p> <p>Unit Hz</p> <p>Min. 0.1</p> <p>Max. 200.0</p> <p>Specified value 10.0</p>
<p>Low-pass filter analog output active</p>	<p>Here, the status of the low-pass filter for the analog output is indicated.</p> <p>Min. 0</p> <p>Max. 1</p> <p>Specified value 1</p> <p>0 = no, inactive, 1 = yes, active</p>

<p>Limit frequency low-pass filter analog output</p>	<p>The amplifier features a low-pass filter that filters the signal of the analog voltage output. This filter is used for suppressing undesired interference signals. Using this parameter, the limit frequency of the filter is adjusted.</p> <p>This low-pass filter is independent from the EtherCAT® filter.</p> <p>Unit Hz</p> <p>Min. 0.1</p> <p>Max. 200.0</p> <p>Specified value 10.0</p>
<p>Analog output scaling</p>	<p>This parameter determines, for which force the analog output outputs its maximum voltage (10 V).</p> <p>Note:</p> <p>If lb (pound) is selected, the system switches from metric to imperial measuring units.</p> <p>Unit N</p> <p>Min. 0.1</p> <p>Max. 200'000.00</p> <p>Specified value 1'000.00</p>

7.2 Cyclic Data Traffic

After a successful system start the EtherCAT® master and the assigned EtherCAT® slaves can exchange cyclic process data. The table below shows the measured data and how they are transmitted.

Parameter	
Name	Description
Actual value in ADC	<p>Value read in via the A/D converter.</p> <p>Data type int (signed 16 bit)</p> <p>Value range -16384 to 16384</p> <p>Value format ±#####</p> <p>The value is interpreted as integer without decimal place. E.g. 1000 = 1000 ADC raw value</p>
Actual value in Newton	<p>Filtered actual value converted into Newton</p> <p>Data type long (signed 32 bit)</p> <p>Value range ±200'000'000</p> <p>Value format ±#####.###</p> <p>The value is interpreted as decimal number with 3 decimal places. E.g. 1500 = 1,500 N (1.5 N)</p> <p>Unit N</p>
Actual value in pound	<p>Filtered actual value converted into pound.</p> <p>Data type long (signed 32 bit)</p> <p>Value range ±200'000'000</p> <p>Value format ±#####.###</p> <p>The value is interpreted as decimal number with 3 decimal places. E.g. 224820 = 224,820 lb (224.82 lb)</p> <p>Unit lb</p>

<p>Actual value in unit</p>	<p>Filtered actual value converted into configured unit.</p> <p>Data type long (signed 32 bit)</p> <p>Value range -2'147'483'648 to 2'147'483'647</p> <p>Value format ±#####.### for N, kN, kg, oder lb</p> <p>The value is interpreted as decimal number with 3 decimal places. E.g. unit set to kN 100000 = 100.000 kN (100kN)</p> <p>Wertformat ±#####.# for g</p> <p>The value is interpreted as decimal number with 1 decimal place. E.g. unit set to g 12340 = 1234,0 g (1234 g)</p> <p>Unit N, kN, g, kg, or lb</p>
<p>Status</p>	<p>The status contains information about the current process and operating condition.</p> <p>Every bit represents a separate event. The condition is active, if the bit is set.</p> <p>Data type byte (unsigned 8 bit)</p> <p>Bit 0 Overload (LSB)</p> <p>Bit 1 Analog output overflow</p> <p>Bit 2 Analog output underflow</p>

7.3 Acyclic Data Traffic

After a successful system start the EtherCAT® master the assigned EtherCAT® slaves can exchange acyclic requirement data. The following table shows the parameters and commands and how they are transmitted using acyclic data traffic.

To address the parameter group "Force Values Configuration" the index 0x2800 and sub index 0x01 to 0x08 have to be used.

Parameter	
Index 0x2800 Sub index	Description
0x01	<p>Unit</p> <p>Access type R/W</p> <p>Parameter command unit</p> <p>Data type byte (unsigned 8 bit)</p> <p>Value range 0 to 4 0=N; 1=kN; 2=lb; 3=g; 4=kg</p> <p>Value format #</p>
0x02	<p>Offset</p> <p>Access type R/W</p> <p>Parameter command offset</p> <p>Data type int (unsigned 16 bit)</p> <p>Value range -16'000 to 16'000</p> <p>Value format ±#####</p>
0x03	<p>Gain</p> <p>Access type R/W</p> <p>Parameter command gain</p> <p>Data type int (unsigned 16 bit)</p> <p>Value range 100 to 20'000</p> <p>Value format ##.###</p>

<p>0x04</p>	<p>System force</p> <p>The system force is the maximum permissible force of the used measuring system.</p> <p>Access type R/W</p> <p>Parameter command system force</p> <p>Data type long (unsigned 32 bit)</p> <p>Value range 0 to 200'000'000</p> <p>Value format #####.###</p> <p>Unit N</p>
<p>0x05</p>	<p>Low-pass filter active</p> <p>Switch the low-pass filter actual value on or off; 0 = off; 1 = on.</p> <p>Not remanent: The adjusted value is lost on a restart! This filter is switched on after a restart.</p> <p>Access type R/W</p> <p>Parameter command low-pass filter actual value active (EtherCAT®)</p> <p>Data type byte (unsigned 8 bit)</p> <p>Value range 0 to 1</p> <p>Value format #</p>
<p>0x06</p>	<p>Limit frequency low-pass filter actual value</p> <p>Limit frequency of the low-pass filter for the actual value outputted via EtherCAT®.</p> <p>Access type R/W</p> <p>Parameter command limit frequency low-pass filter actual value (EtherCAT®)</p> <p>Data type int (unsigned 16 bit)</p> <p>Value range 1 to 2'000</p> <p>Value format ###.#</p> <p>Unit Hz</p>

<p>0x07</p>	<p>Offset adjustment</p> <p>Determine and store offset. The system is set to zero without material tension.</p> <p>Access type W</p> <p>Parameter command offset adjustment</p> <p>Data type byte (unsigned 8 bit)</p> <p>Value range 0 to 1</p> <p>Value format #</p>
<p>0x08</p>	<p>Calibration</p> <p>Calibrates the amplifier to the weight in Newton, which is handed over here. It must match the suspended weight.</p> <p>Access type W</p> <p>Parameter command calibration</p> <p>Data type long (signed 32 bit)</p> <p>Value range 0 to 200'000'000</p> <p>Value format #####.###</p> <p>Unit N</p>

Explanation of access types: R = Read, W = Write, R/W = Read and Write.

To address the parameter group "Analog Output Configuration" you have to use index 0x2820 and subindex 0x01 to 0x03.

Parameter	
Index 0x2820 Sub index	Description
<p>0x01</p>	<p>Analog output scaling</p> <p>Determines, at which force the analog output outputs the maximum value of 10 V.</p> <p>Access type R/W</p> <p>Parameter command analog output scaling</p> <p>Data type long (unsigned 32 bit)</p> <p>Value range 100 to 200'000'000</p> <p>Value format #####.###</p> <p>Unit N</p>

0x02	<p>Low-pass filter analog output active</p> <p>Switch the low-pass filter analog output on or off; 0 = off; 1 = on.</p> <p>Not remanent: The adjusted value is lost on a restart! This filter is switched on after a restart.</p> <p>Access type R/W</p> <p>Parameter command low-pass filter analog output active</p> <p>Data type byte (unsigned 8 bit)</p> <p>Value range 0 to 1</p> <p>Value format #</p>
0x03	<p>Limit frequency low-pass filter analog output</p> <p>Limit frequency of the low-pass filter for the actual value outputted via the analog output.</p> <p>Access type R/W</p> <p>Parameter command limit frequency low-pass filter analog output</p> <p>Data type int (unsigned 16 bit)</p> <p>Value range 1 to 2'000</p> <p>Value format ###.#</p> <p>Unit Hz</p>

Explanation of access types: R = Read, W = Write, R/W = Read and Write.

8 EtherCAT® Communication

The acyclic data exchange is provided according to the ESI file

8.1 Services and Protocols

The following services and protocols are used:

- SDO client and server side protocol (CoE)
- File Access over EtherCAT® (FoE)

All other services required for EtherCAT® are permissible as well.

The services above can be used with the EMGZ491.ECAT at any time.

9 Dimensions

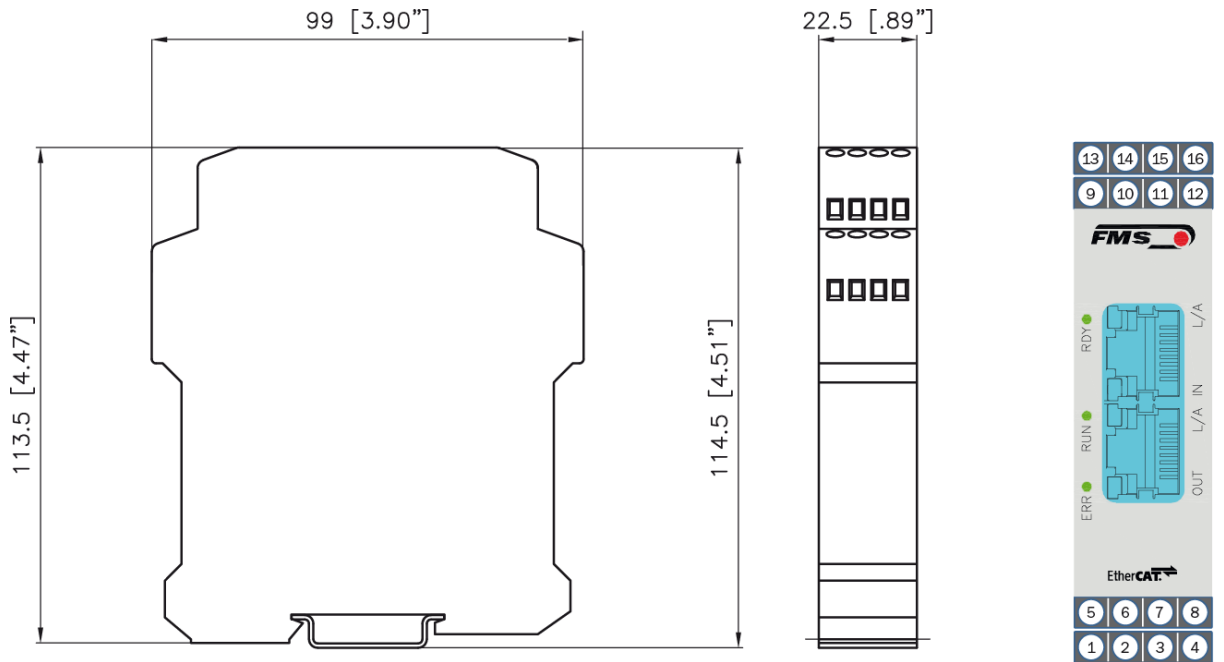

Figure 8: EMGZ491.R.ECAT housing for DIN rail mounting

EMGZ491_ECAT_Grafik.ai

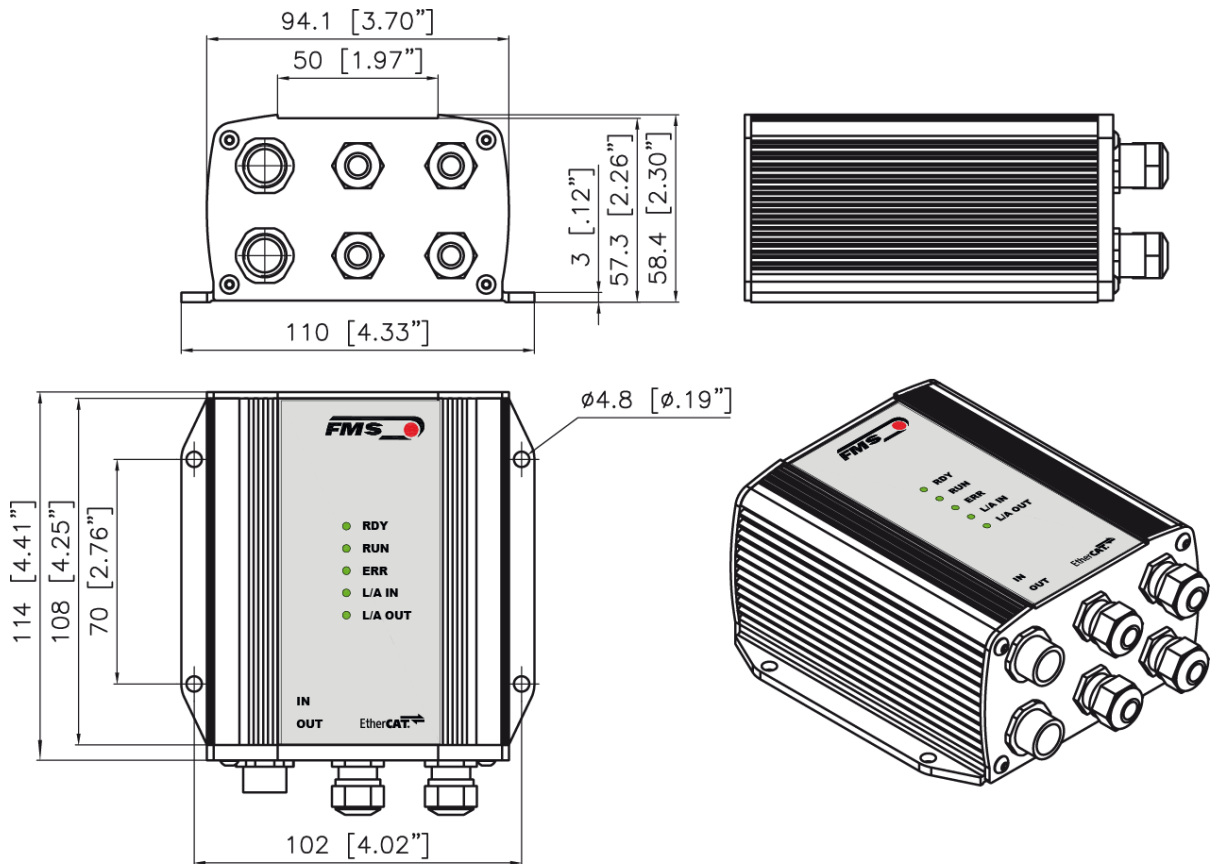

Figure 9: EMGZ491.W.ECAT housing for wall mounting

EMGZ491_ECAT_Grafik.ai

10 Technical Data

Technical data	
Number of channels	1 channel for max. 2 force sensors
Excitation voltage	5 VDC
Sensor feedback signal	± 9 mV (max. 12.5 mV) Option V05 ± 2.5 mV
A/D converter resolution	± 32'768 digit (16 bit)
D/A converter resolution	0 to 4'096 (12 bit)
Measuring inaccuracy	< 0.05 % FS
Connector for interface	EMGZ 491.R.ECAT: 2 x RJ-45 EMGZ 491.W.ECAT: 2 x M 12 4-pole, D-coded
Configuration	via EtherCAT®
Protection class	IP 20 (.R version); IP 65 (.W version)
Power supply	24 VDC (18 to 36 VDC)
Power consumption	5 W
Temperature range	-10 to +50 °C (14 to 122 °F)
Weight	370 g / 0.82 lbs (.R version); 470 g / 1.04 lbs (.W version)

EtherCAT® characteristics	
Cycle time	≥ 1 ms in Free Run Mode
Baud rate	100 Mbit /s
Cyclic process data	PDO with fixed mapping
Acyclic communication	SDO Master-Slave
Supported protocols	SDO client and server side protocol (CoE); File Access over EtherCAT (FoE)
CoE (CAN application layer over EtherCAT)	SDO Upload, SDO Download, SDO Information Service (Object Dictionary)
Mailbox Size	Fix length of 128 Byte
SII (Slave Information Interface)	4 kB
Type	Complex Slave
FMMUs	8
SYNC Manager	4
Explicit Device Identification	Set Device Identification by Configuration Tool



FMS Force Measuring Systems AG
Aspstrasse 6
8154 Oberglatt (Switzerland)
Tel. 0041 1 852 80 80
Fax 0041 1 850 60 06
info@fms-technology.com
www.fms-technology.com

FMS USA, Inc.
2155 Stonington Avenue Suite 119
Hoffman Estates., IL 60169 (USA)
Tel. +1 847 519 4400
Fax +1 847 519 4401
fmsusa@fms-technology.com

FMS (UK)
Highfield, Atch Lench Road
Church Lench
Evesham WR11 4UG (Great Britain)
Tel. 01386 871023
Fax 01386 871021
fmsuk@fms-technology.com

FMS Italy
Via Baranzate 67
20026 Novate Milanese
Phone +39 02 39487035
Fax +39 02 39487035
fmsit@fms-technology.com