



Operating Manual EMGZ309

Digital Microprocessor Controlled Tension Amplifier

Version 2.12 08/2017 NS
Firmware Version V2.10



Diese Bedienungsanleitung ist auch in Deutsch erhältlich.
Bitte kontaktieren Sie Ihren nächstgelegenen FMS Vertreter.

Table of contents

| | | |
|----------|---|-----------|
| 1 | Safety Instructions..... | 3 |
| 1.1 | Description conditions | 3 |
| 1.2 | List of safety instructions | 3 |
| 2 | System Description..... | 4 |
| 2.1 | Functional description | 4 |
| 2.2 | Block Diagram | 4 |
| 3 | Quick Installation Guide..... | 5 |
| 3.1 | Preparations for Set-up | 5 |
| 3.2 | Installation Procedure | 5 |
| 3.3 | Installation and wiring | 5 |
| 3.4 | Mounting the Force Sensors | 6 |
| 3.5 | Wiring the Amplifier | 6 |
| 4 | Configuring the Amplifier..... | 8 |
| 4.1 | Power up the EMGZ 309 | 8 |
| 4.2 | Operating Panel | 8 |
| 4.3 | Change the Measuring Units | 8 |
| 4.4 | Change the Device Mode | 9 |
| 4.5 | Offset Compensation | 9 |
| 4.6 | Offset Compensation over the Operating Panel | 9 |
| 4.7 | Calibration | 10 |
| 4.8 | Calibration over the Operating Panel | 11 |
| 5 | Operation..... | 12 |
| 5.1 | Operating the EMGZ309 over the Operating Panel | 12 |
| 5.2 | Display Value Selection State | 13 |
| 5.3 | Displaying of Overload, Over and Underflow | 13 |
| 6 | Parameterization over the Operating Panel | 14 |
| 6.1 | Reset to Default Parameter Set | 16 |
| 6.2 | Parameter List | 17 |
| 6.3 | Description of Parameters | 18 |
| 7 | Parameter Setting via a PC | 23 |
| 7.1 | Parameterization in an Ethernet Network via Web Browser | 24 |
| 7.2 | Offset Compensation via the Web Browser | 27 |
| 7.3 | Calibration via the Web Browser | 28 |
| 7.4 | Connecting the EMGZ309 Amplifier with a PC (Peer-to-Peer) | 30 |
| 8 | Dimensions..... | 33 |
| 9 | Technical Specification | 35 |

1 Safety Instructions

1.1 Description conditions

a) High danger of health injury or loss of life



Danger

This symbol refers to high risk for persons to get health injury or loss of life. It has to be followed strictly.

b) Risk of damage of machines



Caution

This symbol refers to informations, that, if ignored, could cause heavy mechanical damage. This warning has to be followed absolutely.





c) Note for proper function



Note

This symbol refers to an important information about proper use. If not followed, malfunction can be the result.

1.2 List of safety instructions

-  **Proper function of the Tension Measuring Amplifier is only guaranteed with the recommended application of the components. In case of other arrangement, heavy malfunction can be the result. Therefore, the installation instructions on the following pages must be followed strictly.**
-  **Local installation regulations are to preserve safety of electric equipment. They are not taken into consideration by this operating manual. However, they have to be followed strictly.**
-  **Bad earth connection may cause electric shock to persons, malfunction of the total system or damage of the electronic unit! It is vital to ensure that proper earth connection is done.**
-  **Improper handling of the electronic boards may cause damage to the fragile equipment! Don't use rough tools such as screwdrivers or pliers! Operators handling the electronic boards must wear a well earthed bracelet in order to discharge static electricity.**

2 System Description

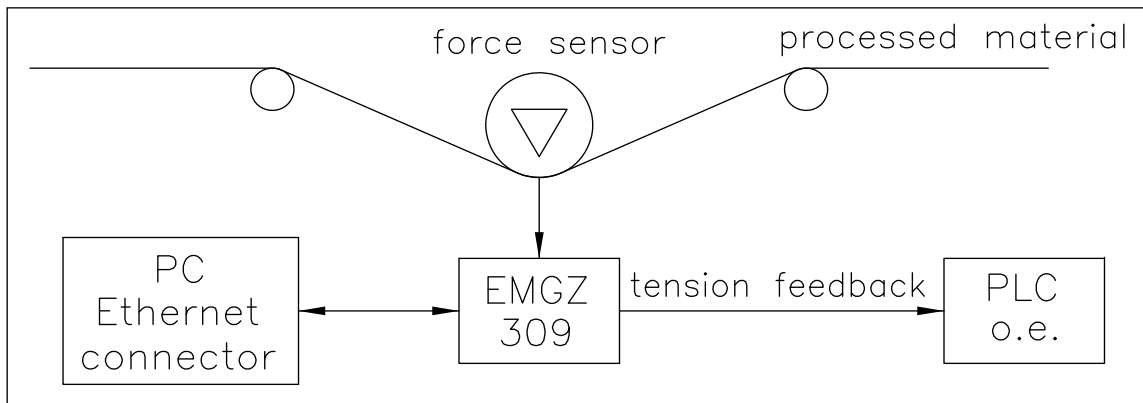

Fig. 1: System Configuration EMGZ309 Tension Measuring Amplifier E309012e

2.1 Functional description

The digital tension measuring amplifiers EMGZ309 are suitable for tension measurement with all FMS force sensors. This versatile product comes as a plug & play unit and is very easy to setup through the operating panel. Alternatively, more advanced users can access all the internal parameters through a Web Browser and set up the device over a PC. The amplifier is then either connected to a network (e.i. Ethernet) or via a peer-to-peer configuration to a laptop or local PC. A wealth of options allows the optimization of the amplifier to almost any application.

2.2 Block Diagram

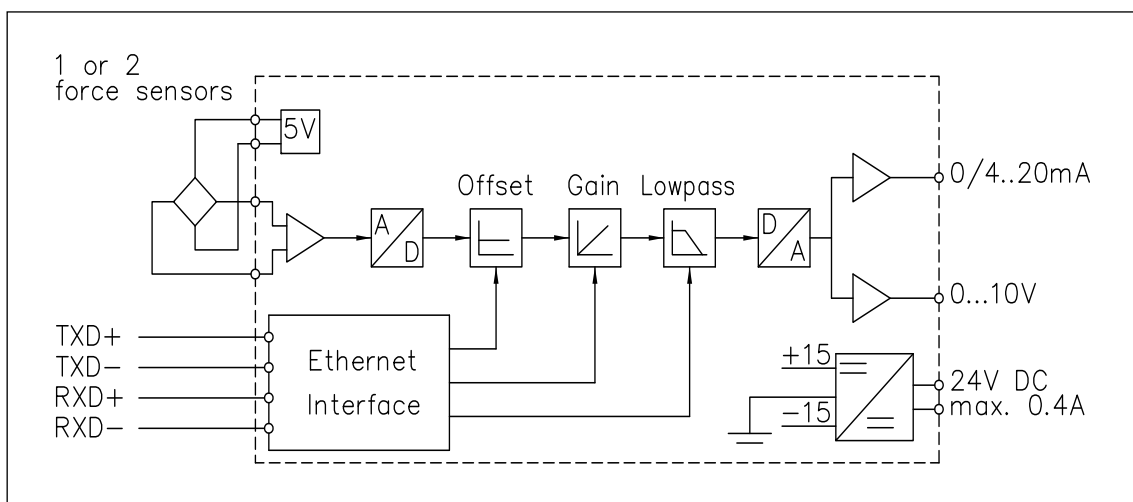

Fig. 2: Block diagram EMGZ309 Tension Measuring Amplifier E309011e

3 Quick Installation Guide

In a Plug & Play configuration the set-up of the EMGZ309 and force sensor is limited to only the offset compensation and the calibration.

3.1 Preparations for Set-up

1. Read the Operation Manual of your force measuring sensors
2. Check your requirements such as:
 - Desired output configuration 0...10V or 0/4... 20mA
 - Display unit of nominal force
3. Draw the wiring diagram for your configuration (ref. to 3.5 “Wiring the Amplifier“)
4. If required, determine special parameters (ref. to 6 “Parameterization over Operating Panel”)

3.2 Installation Procedure

1. Mount your force measuring sensors to the machine frame (ref. to paragraph 3.4)
2. Wire the Force Measuring Sensor(s) (ref. to Fig. 3)
3. Connect the amplifier to the power supply.
4. The power supply voltage must be in the range 18 to 36V DC.
5. Perform offset compensation and calibration (ref. to chapters 4.5 to 4.9)
6. If required, do additional settings (ref. to 6 “Parameterization over Operating Panel”)

3.3 Installation and wiring



Caution

In order to improve the natural convection and keep the temperature of the amplifiers that are mounted in a cabinet, to a minimum, a distance of at least 15mm (0.6”) between the devices must be kept.



Caution

Proper function of the Tension Measuring Amplifier is only guaranteed with the recommended application of the components. In case of other arrangement, heavy malfunction can be the result. Therefore, the installation instructions on the following pages must be followed strictly.

**Caution**

Local installation regulations are to preserve safety of electric equipment. They are not taken into consideration by this operating manual. However, they have to be followed strictly.

3.4 Mounting the Force Sensors

Mounting of the force sensors is done according to the FMS Installation manual which is delivered together with the force sensors.

3.5 Wiring the Amplifier

One or two force sensors can be connected to the measuring amplifier. When using two force sensors, the sensors are internally connected in parallel. The output signal of the measuring amplifier will then correspond to the average value of the two sensors.

The connection between force sensors and measuring amplifier has to be done using a $2 \times 2 \times 0.25 \text{ mm}^2$ [AWG 23] shielded twisted-pair cable. The cable must be installed separate from power lines.

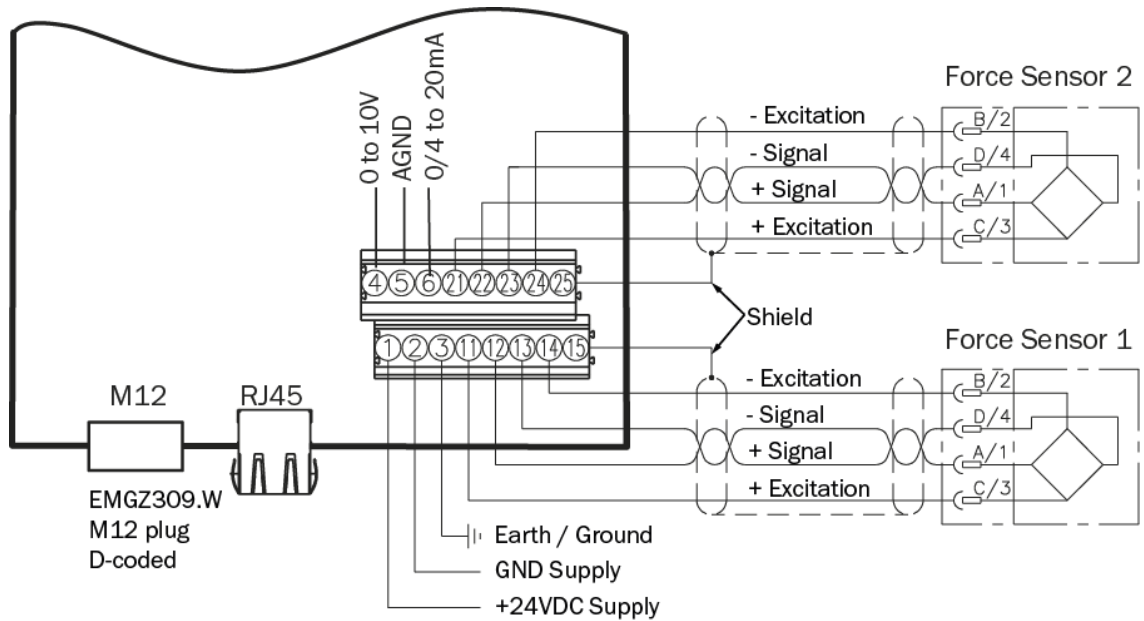



Fig. 3: Wiring Diagram EMGZ309

EMGZ_309_BA_Manual.ai

| Signal | Name | EIA T568B | Pin RJ45 | Pin M12 |
|--------|---------------------|-----------|----------|---------|
| TD+ | Transmission Data + | WH/OG | 1 | 1 |
| TD- | Transmission Data - | OG | 2 | 3 |
| RD+ | Receive Data + | WH/GN | 3 | 2 |
| RD- | Receive Data - | GN | 6 | 4 |

Ethernet connectors

EMGZ_309_BA_Manual.ai



Caution
Bad earth ground connection may cause electric shock to persons, malfunction of the total system or damage of the electronic unit! It is vital to ensure that proper earth connection is done.



Note
The shield should be connected only to the electronic unit. On the force sensor side the shield should stay open.

4 Configuring the Amplifier

4.1 Power up the EMGZ 309

1. Connect the first force sensor (see Fig.3 Wiring Diagram EMGZ309)
2. Check whether applying a force in measuring direction (in the direction of the red point) on the first sensor results in a positive output signal. If not, exchange the two signal wires of the corresponding force sensor in the terminal block (terminals 12/13).
3. If applicable, connect the second force sensor.
4. Check whether applying a force in measuring direction on the second sensor results in a positive output signal. If not, exchange the two signal wires of the corresponding force sensor in the terminal block (terminals 22/23)

4.2 Operating Panel

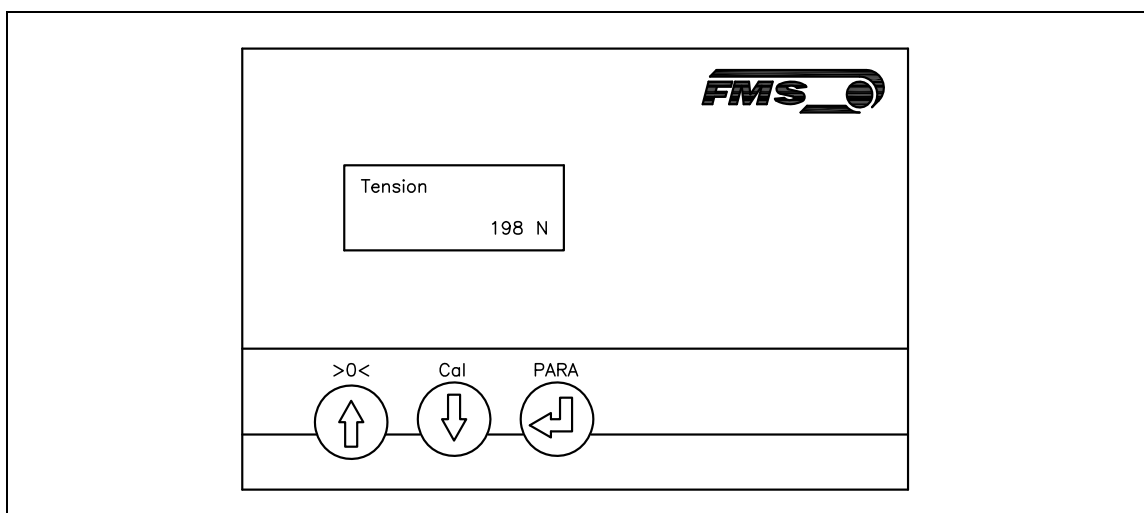



Fig. 4: Operating Panel EMGZ309.W





E309007e

The keys on the operating panel have the following functions:

| Key | Key Function |
|---|---|
|  | Change the selections or increase / decrease the values |
|  | Enter |
| >0< + PARA | Enter Offset Compensation Procedure. Press the two keys at the same time for longer then 3 sec. |
| Cal + PARA | Enter Calibration Procedure. Press the two keys at the same time for longer then 3 sec. |
| PARA | Enter the Parameter Setting Mode. Press the key at the same time for longer then 3 sec. |

4.3 Change the Measuring Units



The default tension measuring units is N (Newton). The user can, however, select another unit before the calibration process. To select the units of measure, follow the steps below:

1. Hold the **PARA** key until the display changes to [Dis. Filt]
2. Scroll the menu by pressing the  key until the display shows [Unit]
3. Press the  and the word [Unit] will start flashing indicating that the unit of measure can now be changed.
4. With every press of the   keys the display will change from N, kN, then to lb, g, kg.
5. Stop at the desired unit and press the  again to confirm the selection.
6. Press the **PARA** key for longer then 3 sec. to save the setting and return to the Operating State. Or if no action is taken after 30 seconds, the value will be stored in the system automatically.

4.4 Change the Device Mode

The EMGZ309 amplifiers have two Device Modes:

- **Display of Force Gauge:** Tension data are displayed in a force unit
- **Display of Voltage Gauge:** Tension data are displayed in Volt (V)

1. Go to Parameter Selection Mode (press **PARA** key longer than 3 sec).
2. Go to Parameter [DevicMod]
3. With the key  select desired Device Mode [ForcGaug] or [VoltGaug] and confirm selection with the key .



Note

Each change of the Device Mode requires a re-calibration of the system (see chapter 4.8).

4.5 Offset Compensation

With the Offset Compensation you can compensate the roller weight. It is always performed before the calibration. The Force Measuring Sensor should not be loaded while the Offset Compensation is being done. There are two possible ways performing the offset compensation.

- A) Offset compensation over the operating panel (see **chapter 4.6**)
- B) Offset compensation via the Web Browser.
For this method proceed to **chapter 7.2; Fig. 22 and 23.**

4.6 Offset Compensation over the Operating Panel

1. Press the two keys >0< and **PARA** at the same time for longer then 3 seconds.
2. The display will show [Offset Complete] when the process is finished (see **Fig. 5** State diagram offset compensation).

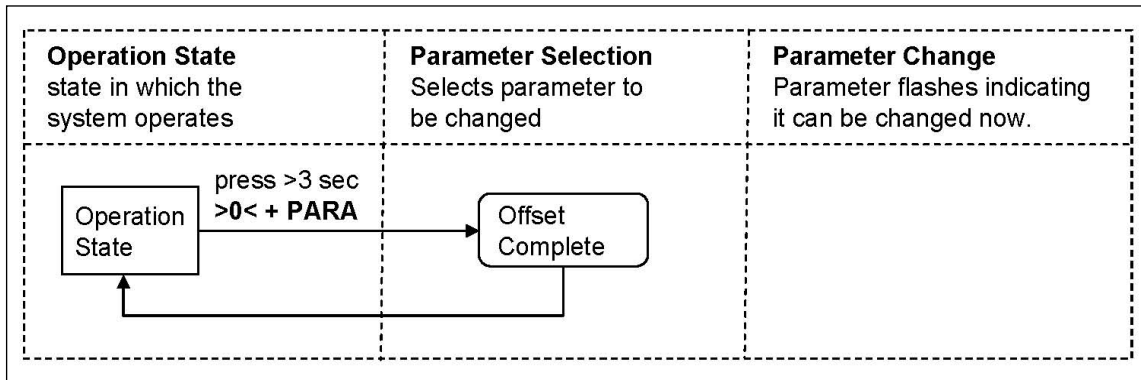

Fig. 5: State diagram offset compensation

EMGZ309013e

4.7 Calibration

By calibrating (setting the Gain), amplifier and load cells are adjust so that the display gives the actual tension value. The method uses a defined weight (see Fig. 6). This method is the preferred one since it delivers the most accurate results. The calibration can be performed over the Operation Panel or via the Web Browser. For the later proceed to chapter 7.3, Fig. 22 and 23.

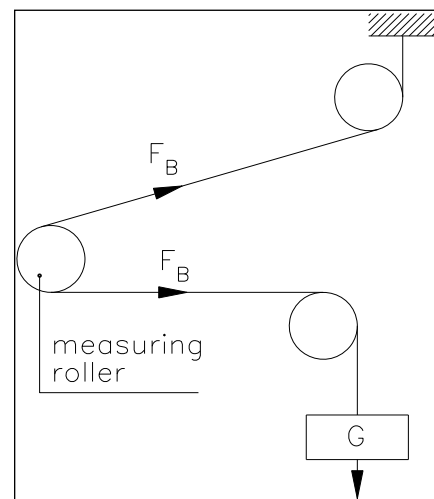

Fig. 6: Calibrating the measuring amplifier

C431011e



Note

If the Device Mode is set to [VoltGaug], the force corresponding to the calibration weight must be input in Volt (V) in the following calibration procedure. The parameters System Force [SysForce] and Force at maximum output [F@OutMax] won't be requested (see also chapter 7.3, section B).

4.8 Calibration over the Operating Panel

1. Load a rope with a defined weight corresponding to your calibration force on the roller. The roller configuration must correspond to the real configuration in the machine (wrap angle, distance of the rollers etc.).
2. Enter calibration mode by pressing the two keys **Cal** and **PARA** at the same time for longer than 3 seconds. The display changes to

SysForce
1000.0 N
3. The System Force [**SysForce**] determines the measuring capability of your measuring roller. E.g. if two 500 N sensors are installed, enter 1000N. If only one 500N sensor is used, enter 500N (see 6.2 and 6.3 “Descriptions of Parameter”, [**SysForce**]).
4. The parameter [**SysForce**] flashes indicating that the force can now be changed. Use keys to enter the system force.
5. Press the key to confirm your input. The display changes to

Calibra.
1000.0 N
6. Enter the force corresponding to your calibration weight with the keys.
7. Press the key to confirm your input. The display changes to

F@OutMax
1000.0 N
8. The parameter [**F@OutMax**] determines the force corresponding to the maximum amplifier output (10V or 20mA) (see 6.3 “Descriptions of Parameter”, [**F@MaxOut**]). Enter the value with the keys.
9. Press the key to confirm your input. The display changes to

Calibra.
Complete

The calibration procedure has been completed successfully.

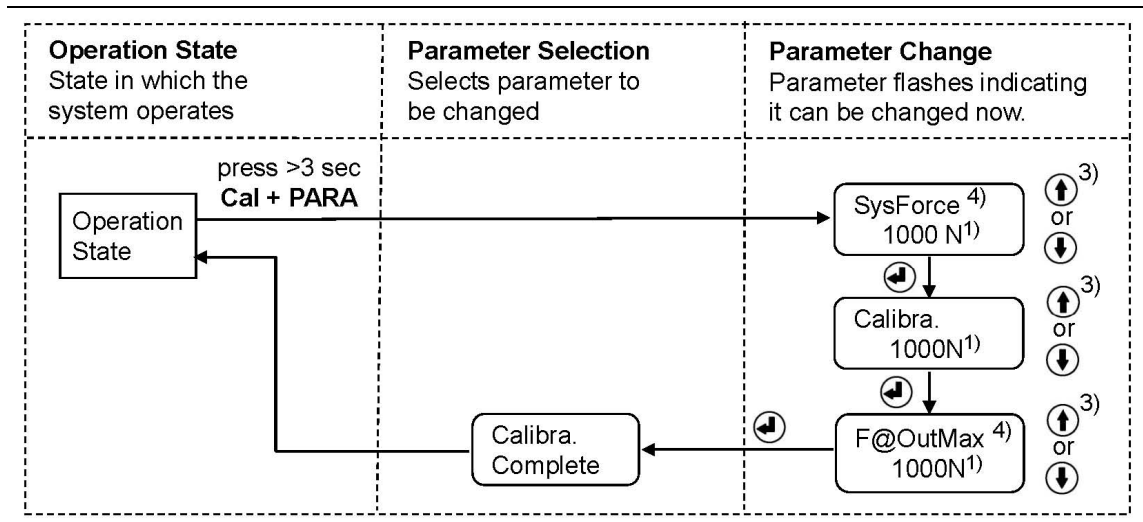

Fig. 7: State diagram calibration

EMGZ309014e

- 1) The display shows the unit of measure that was previously selected.
- 3) Permanent key pressing expedites the changing speed.
- 4) If the Device Mode [**VoltGauge**] is set, these parameters are deactivated

5 Operation

5.1 Operating the EMGZ309 over the Operating Panel

The EMGZ309 amplifier can go in 5 different states:

- **Operation State:** Amplifier operating
- **Display Selection:** Selection of force or output reading
- **Offset Compensation:** Automatic procedure to offset the roller weight
- **Calibration State:** Procedure to calculate the amplifier gain
- **Parameterisation State:** Set or change parameters

When using the front panel, the user can toggle between these modes by pressing a key or a combination of keys. **Fig. 9** provides an overview about the different Operation States and how to move from one state to the other.

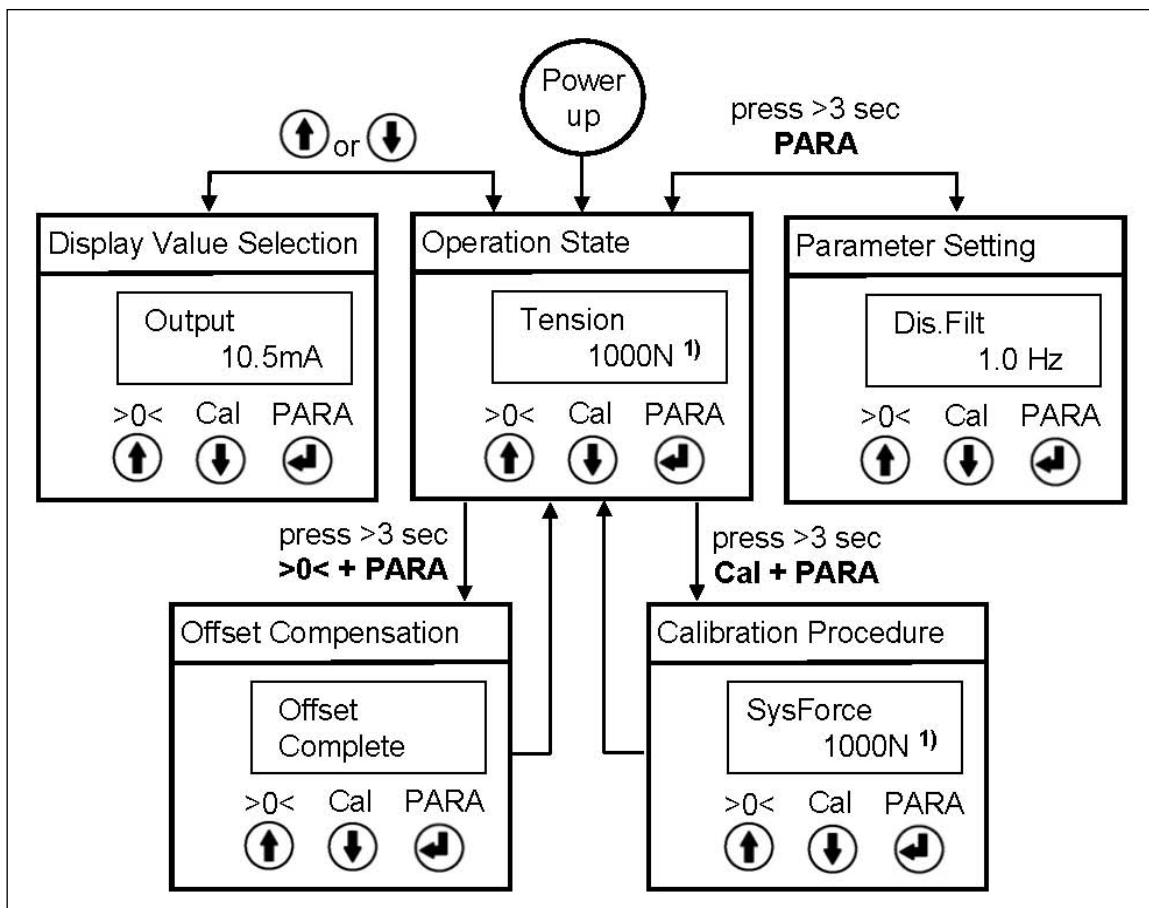

Fig. 9: Top-level view of operation control

E309015e

¹⁾ The display shows the unit of measure that was previously selected.

5.2 Display Value Selection State

The EMGZ309 can display either a tension value or the amplifier output that is an electrical unit corresponding to the measured tension.

A) For tension display following unit can be selected: N, kN, lb, g, kg

B) The amplifier output can be displayed in 0...10VDC, 0...20mA or 4...20mA

5.3 Displaying of Overload, Over and Underflow

In the Operation State the EMGZ309 amplifier will indicate limit violations on the display depending on the chosen unit:

A) If a tension has been chosen, the reading on the display at overload will be:

Overload
1200.0 N

B) If the display was set to show the amplifier output, following messages will be displayed:

At overflow:

Out>Max
20.00 mA

or

Out>Max

At underflow:

Out<Min
0.00

or

Out<Min
0.00 V



Note

An overflow messages is caused by the maximum output value 10V or 20mA being overshoot. An underflow message is caused by the minimum value 0V or 4mA being undershot. The parameter [F@OutMax] can influence the overflow messages. If the actual tension value overflows the value entered in [F@OutMax], an error message will be displayed.

6 Parameterization over the Operating Panel

After offset compensation and calibration the system is configured. It can now be put into operation. The following state diagrams (Fig. 10 -12) help to navigate through the parameter setting menu. In the Parameterisation State the EMGZ309 can be brought into the 2 modes: "Parameter Selection" and "Parameter Change".

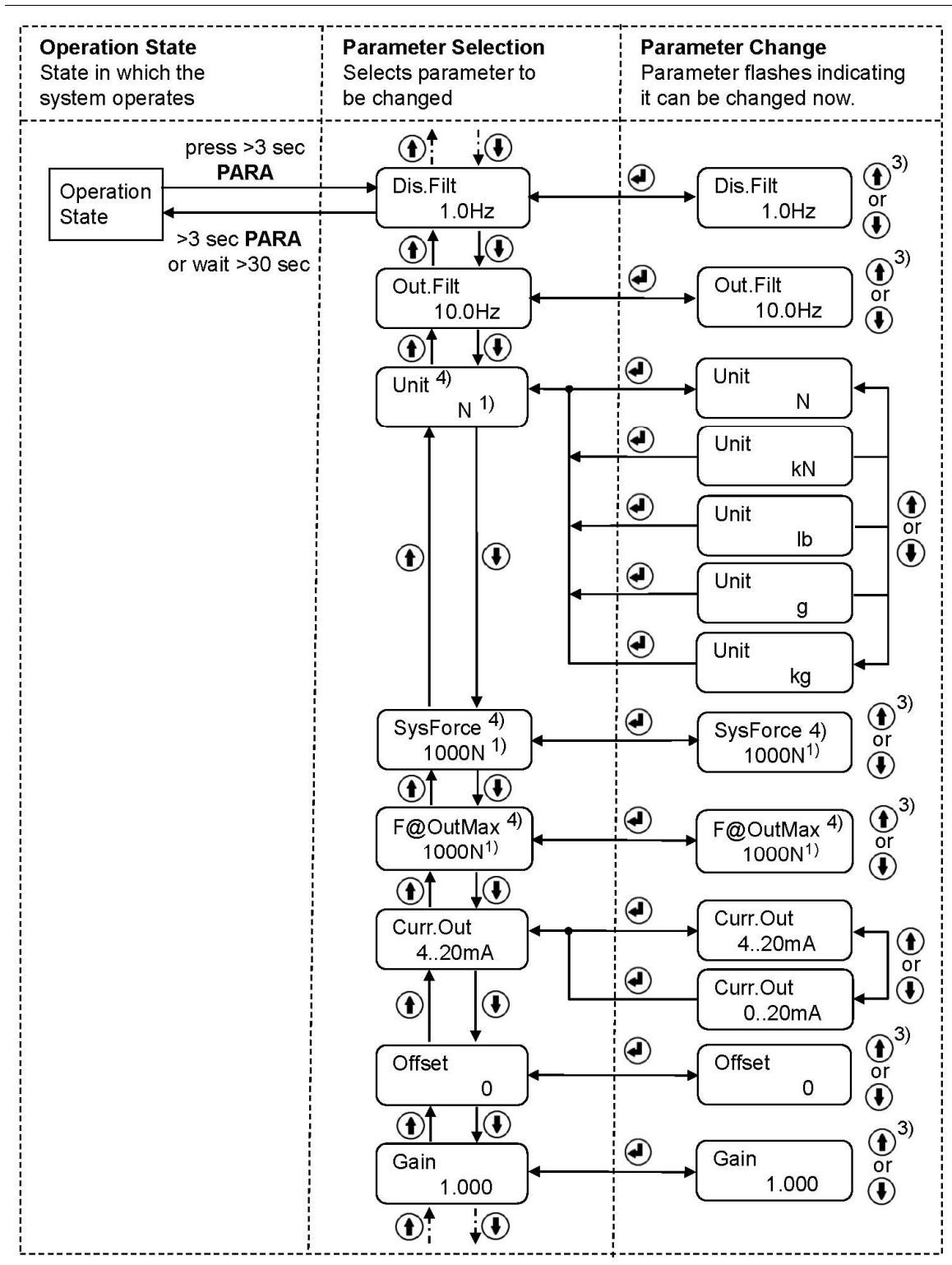

Fig. 10: State Diagram Parameter Setting (1st part)

E309016e

- 1) The display shows the unit of measure that was previously selected.
- 3) Permanent key pressing expedites the changing speed.
- 4) If the Device Mode [VoltGauge] is set, these parameters are deactivated

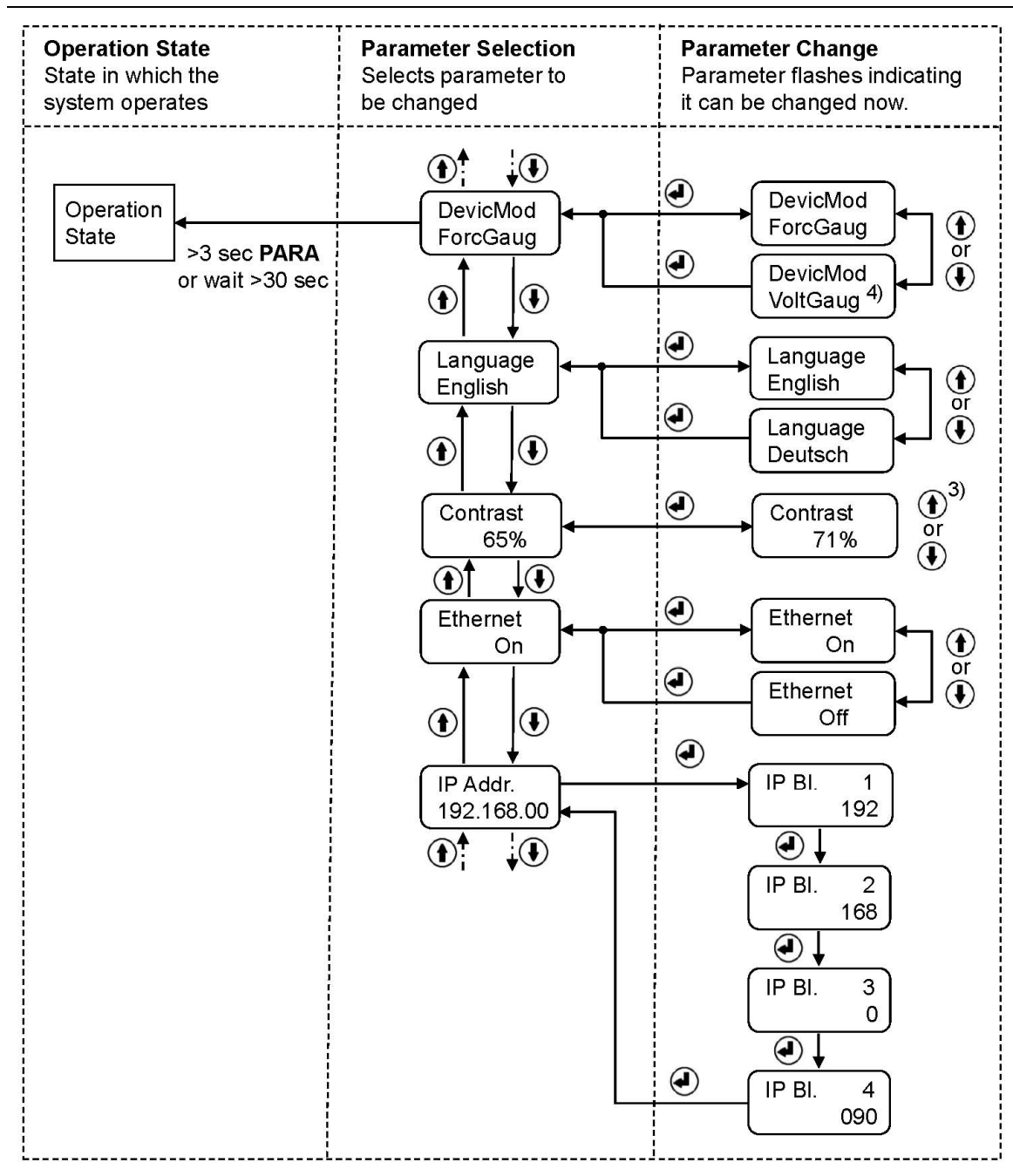

Fig. 11: State Diagram Parameter Setting (2nd part)

E309017e

6.2 Parameter List

| Parameter | Unit | Min | Max | Default | Remarks |
|-------------|---------|----------------------|---------|------------------------|---|
| Dis Filt. | [Hz] | 0.1 | 10.0 | 1.0 | |
| Out Filt. | [Hz] | 0.1 | 200.0 | 10.0 | |
| Unit 4) | [-] | N, kN, lb, g, kg. | | N | |
| SysForce 4) | [N] 1) | 1 | 100'000 | 1000 | |
| F@OutMax 4) | [N] 1) | 1 | 100'000 | 1000 | |
| Curr.Out | mA | 0...20 or 4...20 | | 4...20 | |
| Offset | [Digit] | -8000 | 8000 | 0 | |
| Gain | [-] | 0.100 | 20.000 | 1.000 | |
| DevicMod | [-] | ForcGaug or VoltGaug | | ForcGaug | Each parameter change requires re-calibration |
| Language | [-] | English or German | | English | |
| Contrast | [%] | 1 | 100 | 65 | . |
| Ethernet | [-] | On or Off | | On | If Off, reduces power consumpt |
| IP Addr. | [-] | 0 | 255 | 192 168 0 090 | Address to be entered in 4 blocks |
| Subnet | [-] | 0 | 255 | 255 255 255 0 | Address to be entered in 4 blocks |
| LANSpeed | MBPS | 10 | 100 | 100 | |
| Default | [-] | No, Yes | | Yes | |



1) The display shows the unit of measure that was previously selected.

4) If the Device Mode [VoltGauge] is set, these parameters are deactivated

6.3 Description of Parameters

| Display Filter | | | LCD: <i>Dis.Filt</i> | |
|--|-----------------|------|----------------------|---------|
| <p>Use: The controller provides a low-pass filter to prevent noise overlaying the output signal. The parameter <i>Dis.Filt</i> stores the cut off frequency of the filter. The lower the cut off frequency, the more sluggish the display will be. A correctly tuned filter will steady the value shown in the display. The display filter does not influence the output signal filter described below (parameter <i>Out.Filt</i>).</p> | | | | |
| Unit | Parameter Range | | Selection | Default |
| | Min | Max | | |
| Hz | 0.1 | 10.0 | - | 1.0 |

| Filter Amplifier Output | | | LCD: <i>Out.Filt</i> | |
|---|-----------------|-------|----------------------|---------|
| <p>Use: The EMGZ309 contains a lowpass filter to prevent noise overlaying to the output signal. This parameter stores the cut off frequency of the filter. The lower the cut off frequency, the more sluggish the output signal will be. The filter stabilizes the output signal in case of highly fluctuating force values. This filter is independent from the display filter (see above).</p> | | | | |
| Unit | Parameter Range | | Selection | Default |
| | Min | Max | | |
| Hz | 0.1 | 200.0 | - | 10.0 |

| Unit of Measure | | | LCD: <i>Unit</i> | |
|--|-----------------|-----|---|----------|
| <p>Use: This parameter determines the unit used in the system.</p> <p> By changing the units to lb (pounds) the whole unit system will change from metric to imperial units.</p> <p> If the Device Mode [VoltGauge] is set, this parameter is deactivated</p> | | | | |
| Unit | Parameter Range | | Selection | Default |
| | Min | Max | | |
| - | - | - | <i>N</i> <i>kN</i> <i>lb</i> <i>g</i> <i>kg</i> | <i>N</i> |

| System Force | | | LCD: <i>SysForce</i> | |
|--------------|--|--|----------------------|--|
|--------------|--|--|----------------------|--|

Use: The System Force [**SysForce**] determines the measuring capability of your measuring roller. E.g. If two 500 N sensors are installed in your measuring roller, enter 1000N. If only one 500N sensor is used, enter 500N. If sensors with sheaves are used (e.g. RMGZ-Series), the nominal force 500N must be entered.

 **If the Device Mode [VoltGauge] is set, this parameter is deactivated**

| Unit | Parameter Range | | Selection | Default |
|--------------------------------|-----------------|---------|-----------|---------|
| | Min | Max | | |
| N, kN, g, kg, lb ¹⁾ | 1 | 100'000 | - | 1000 |

¹⁾ The display shows the unit of measure that was previously selected

| Force at max. Amplifier Output | | | LCD: F@OutMax | |
|---|-----------------|---------|---------------|---------|
| Use: This parameter defines what force value (N, kN, lb, g, kg) corresponds to the maximum output of the amplifier (10V or 20mA). | | | | |
|  If the Device Mode [VoltGauge] is set, this parameter is deactivated | | | | |
| Unit | Parameter Range | | Selection | Default |
| | Min | Max | | |
| N, kN, g, kg, lb ¹⁾ | 1 | 100'000 | - | 1000 |

¹⁾ The display shows the unit of measure that was previously selected

| Current Output Selection | | | LCD: Curr.Out | |
|---|-----------------|-----|--------------------|---------|
| Use: This parameter selects the output signal of the amplifier.. | | | | |
| Unit | Parameter Range | | Selection | Default |
| | Min | Max | | |
| - | - | - | 4..20mA 0..20mA | 4..20mA |

| Offset Value | | | LCD: <i>Offset</i> | |
|---|-----------------|-------|--------------------|---------|
| <p>Use: The value determined with the adjustment procedure <i>Offset Compensation</i> is stored as a Digit value in the parameter <i>Offset</i>. The offset value is used to compensate the roller weight (see 4.4 “Offset Compensation”).</p> | | | | |
| Unit | Parameter Range | | Selection | Default |
| | Min | Max | | |
| Digit | -8000 | +8000 | - | 0 |

| Gain of Amplifier | | | LCD: <i>Gain</i> | |
|---|-----------------|--------|------------------|---------|
| <p>Use: This parameter stores the value determined with the Procedure <i>Calibration</i> (see 4.7 “Calibration over the Operating Panel”).</p> | | | | |
| Unit | Parameter Range | | Selection | Default |
| | Min | Max | | |
| - | 0.100 | 20.000 | - | 1.0 |

| Device Mode | | | LCD: <i>DevicMod</i> | |
|--|-----------------|-----|----------------------|----------|
| <p>Use: The Device Mode determines the functionality of the amplifier. If [VoltGaug] is set, force values will be displayed only in Volt (V) or mA. Force units won't be available.</p> | | | | |
| <p> Each change of the Device Mode requires a re-calibration of the system (see chapter 4.8).</p> | | | | |
| Unit | Parameter Range | | Selection | Default |
| | Min | Max | | |
| - | - | - | ForcGaug VoltGaug | ForcGaug |

| Language | | | LCD: <i>Language</i> | |
|---|-----------------|-----|---------------------------------|----------------|
| Use: This parameter determines the language on the LCD. The two languages English and German are available. The menu navigation in the web browser is always in English. | | | | |
| Unit | Parameter Range | | Selection | Default |
| | Min | Max | | |
| - | - | - | <i>English</i> <i>German</i> | <i>English</i> |

| LCD-Contrast | | | LCD: <i>Contrast.</i> | |
|---|-----------------|-----|-----------------------|---------|
| Use: The parameter [Contrast] changes the contrast of the LCD to achieve optimal readability. | | | | |
| Unit | Parameter Range | | Selection | Default |
| | Min | Max | | |
| % | 1 | 100 | - | 65 |

| Ethernet-Interface | | | LCD: <i>Ethernet</i> | |
|--|-----------------|-----|----------------------|---------|
| Use: The Ethernet interface of EMGZ309 can be switched on and off with this parameter. The deactivation of this interface reduces the power consumption by 25% and lowers heat generation in the device considerably. FMS recommends to activated the Ethernet interface only when needed.. | | | | |
| Unit | Parameter Range | | Selection | Default |
| | Min | Max | | |
| - | - | - | On Off | On |

| Ethernet IP Address | | | LCD: <i>IP Addr.</i> | |
|---|--------------------|---------------------|----------------------|--------------------|
| Use: The parameter assigns an IP address to the amplifier. This enables the user to communicate via a web browser with the amplifier that is imbedded in a network. The IP address must be entered in 4 separate blocks (IP Bl. 1; IP Bl. 2; IP Bl. 3; and IP Bl. 4) | | | | |
| Unit | Parameter Range | | Selection | Default |
| | Min | Max | | |
| - | 000.000 000.000 | 255.255. 255.255 | - | 192.168 000.090 |

| Subnet Mask Address | | | LCD: <i>Subnet</i> | |
|--|--|--|--------------------|--|
| Use: The parameter assigns the Subnet Mask of the amplifier in the Ethernet network. This enables the user to communicate via a web | | | | |

| browser with the controller. The Subnet Mask must be entered in 4 separate blocks (Sub. BI 1; Sub. BI 2; Sub. BI 3; and Sub. BI 4). | | | | |
|---|-----------------|----------|-----------|----------|
| Unit | Parameter Range | | Selection | Default |
| | Min | Max | | |
| - | 000.000 | 255.255. | - | 255.255. |
| | 000.000 | 255.255 | | 255.000 |

| LAN Speed | | | LCD: <i>LANSpeed</i> | |
|--|-----------------|-----|----------------------|---------|
| Use: <i>LANSpeed</i> determines the data speed of the tension EMGZ309 amplifier to communicate with the receiver (Switch, Hub or PC). | | | | |
| Unit | Parameter Range | | Selection | Default |
| | Min | Max | | |
| MBPS | | | 100 | 100 |
| | | | 10 | |

| Default Settings | | | LCD: <i>Default</i> | |
|--|-----------------|-----|---------------------|---------|
| Use: This menu point is a command. It resets the parameters to the factory settings. If “No” is chosen, all parameters stay as set by the user. If Yes is chosen, the factory settings are reset. | | | | |
| Unit | Parameter Range | | Selection | Default |
| | Min | Max | | |
| - | - | - | No | No |
| | | | Yes | |

7 Parameter Setting via a PC

Fig 14 shows the EMGZ309 configuration in a LAN (Local Area Network). The EMGZ309 force measuring amplifier can be embedded in an Ethernet network and the parameter setting can be done over this network by means of a web browser (Internet Explorer 7). The devices have a static IP-address that can be set over the user interface. The IP-address is not automatically assigned over DHCP.

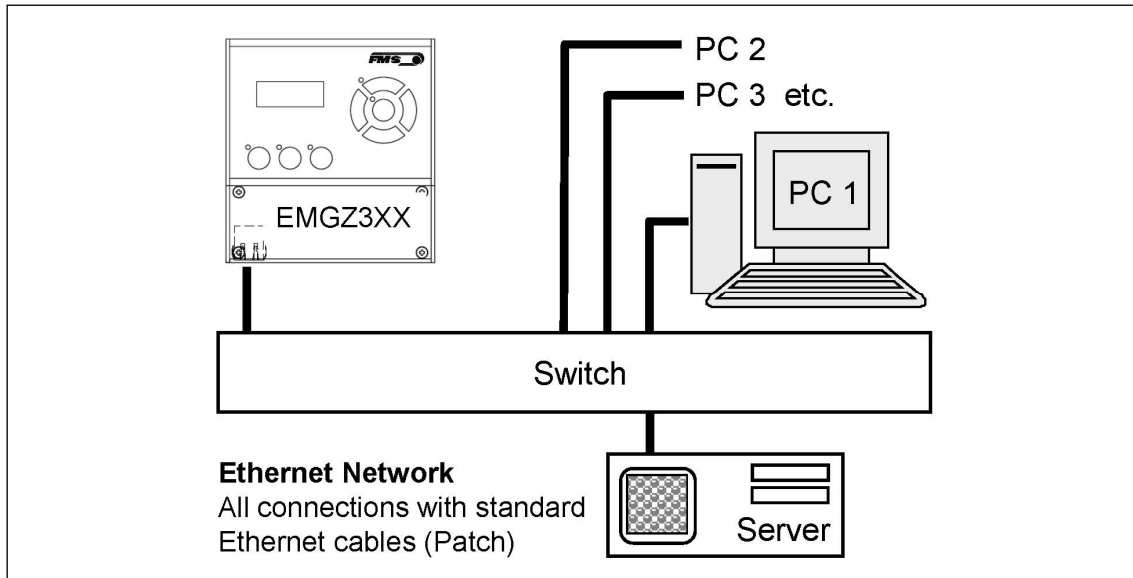

Fig. 14: EMG309 embedded in a LAN

EMGZ309001e

The parameter setting can be carried out with a desktop- or laptop computer via a peer-to-peer connection (see chapter 7.4)

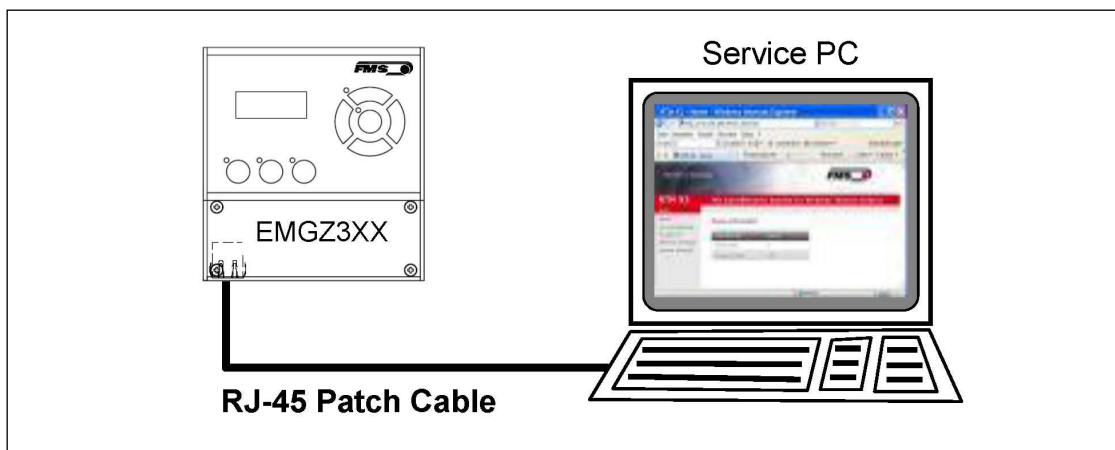

Fig. 15: Connection EMG309 - PC via RJ-45 cable.

E309002e

7.1 Parameterization in an Ethernet Network via Web Browser

The parameterization of the EMGZ309 can be done via an Ethernet network by means of web browser, if the amplifier is embedded in a network. In this case it must be certain that the EMGZ309 uses an IP address in a static block (not assigned by the server). For the integration of an EMGZ309 amplifier in your Ethernet network please contact your IT system administrator.

Once the amplifier was integrated in the network you can address the device e.g. with <http://192.168.0.090> . After establishing the link, the screen Fig. 17 will open up.

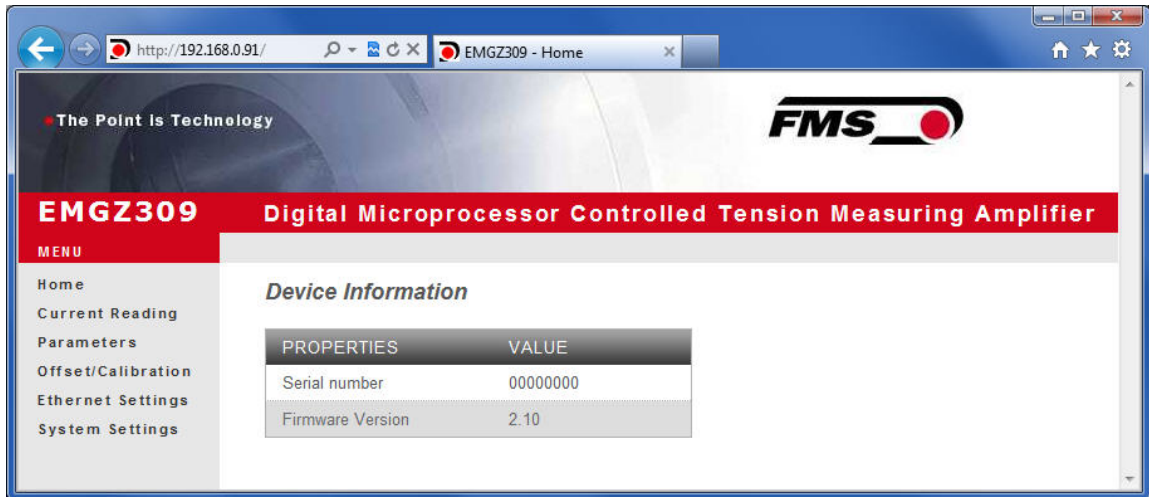

Fig. 17: Home Page with Serial number and device information

Home

Menu on the left side of the screen allows navigation through the web page.



Fig. 18: Current Reading for Device Mode Force Gauge

Current Reading Force

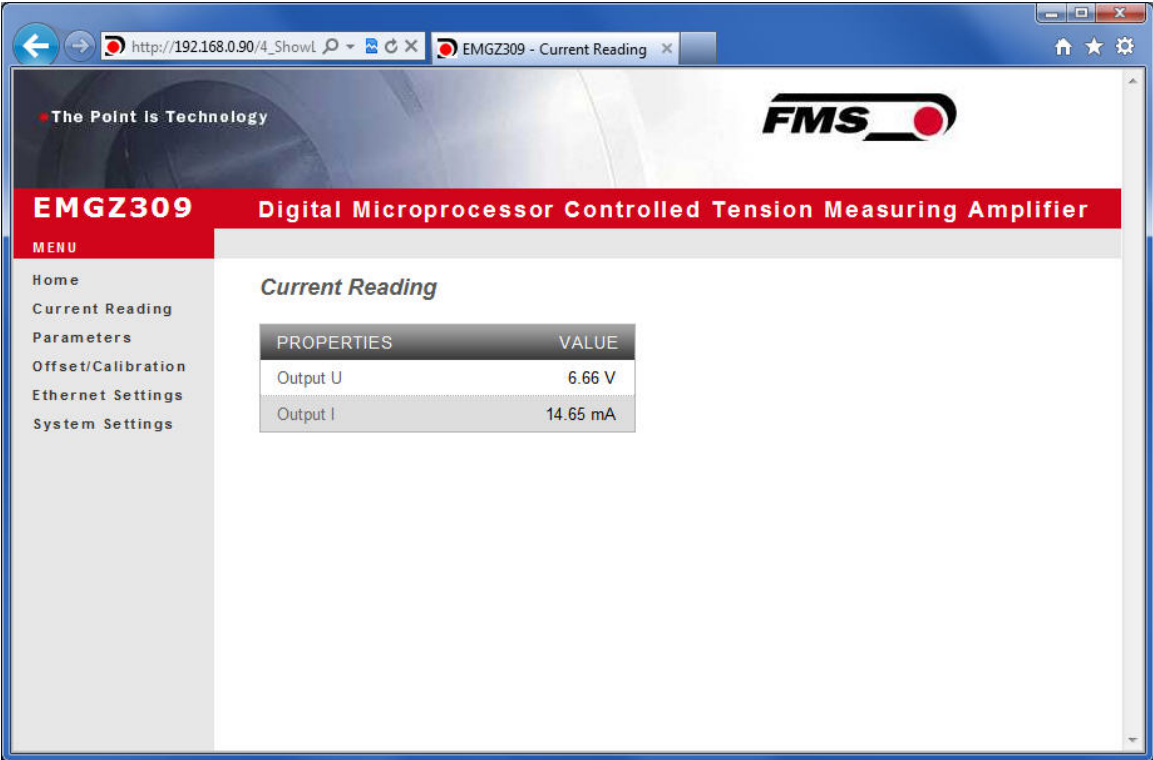

Fig. 19: Current Reading for Device Mode Volt Gauge

Current Reading Volt

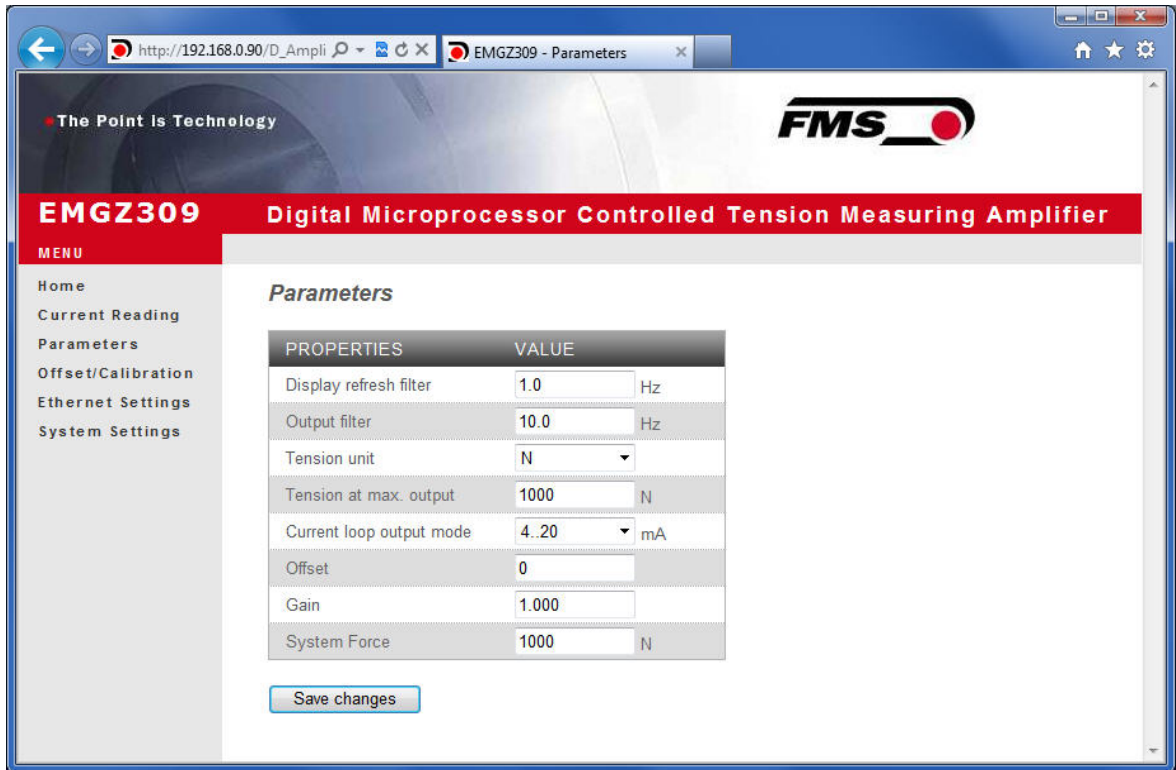

Fig. 20: Parameter list for Device Mode Force Gauge

Parameters-Force

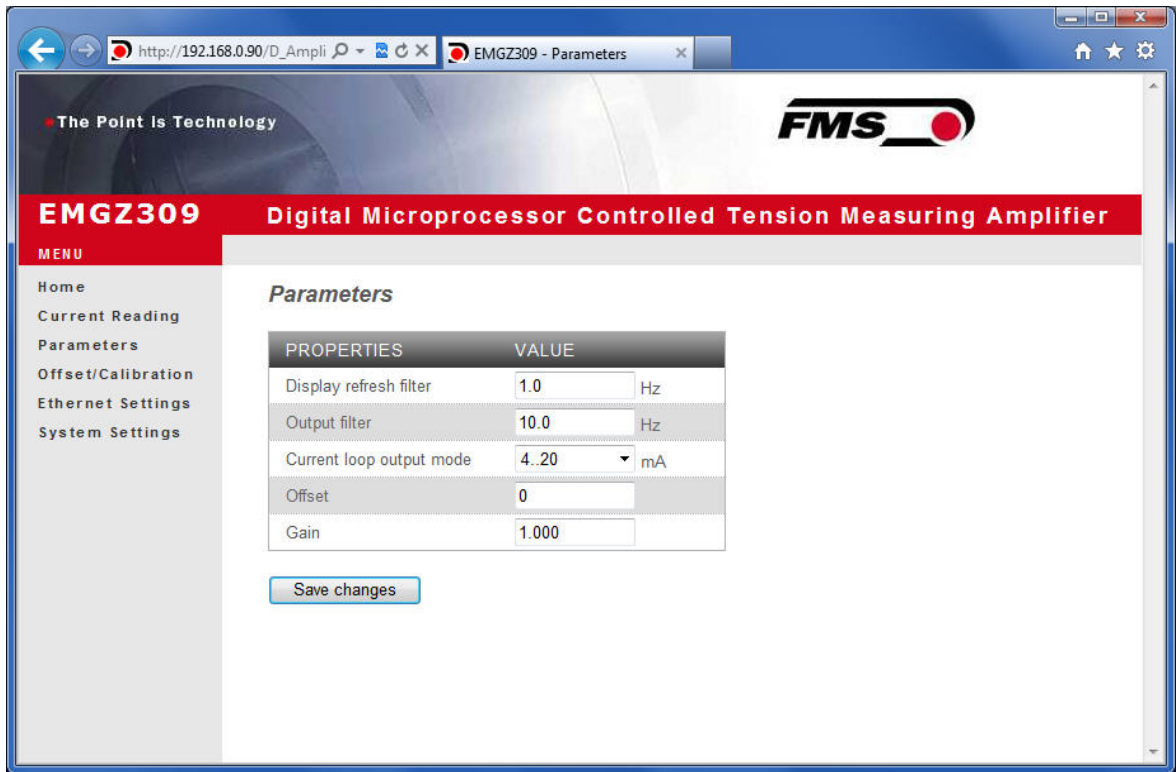
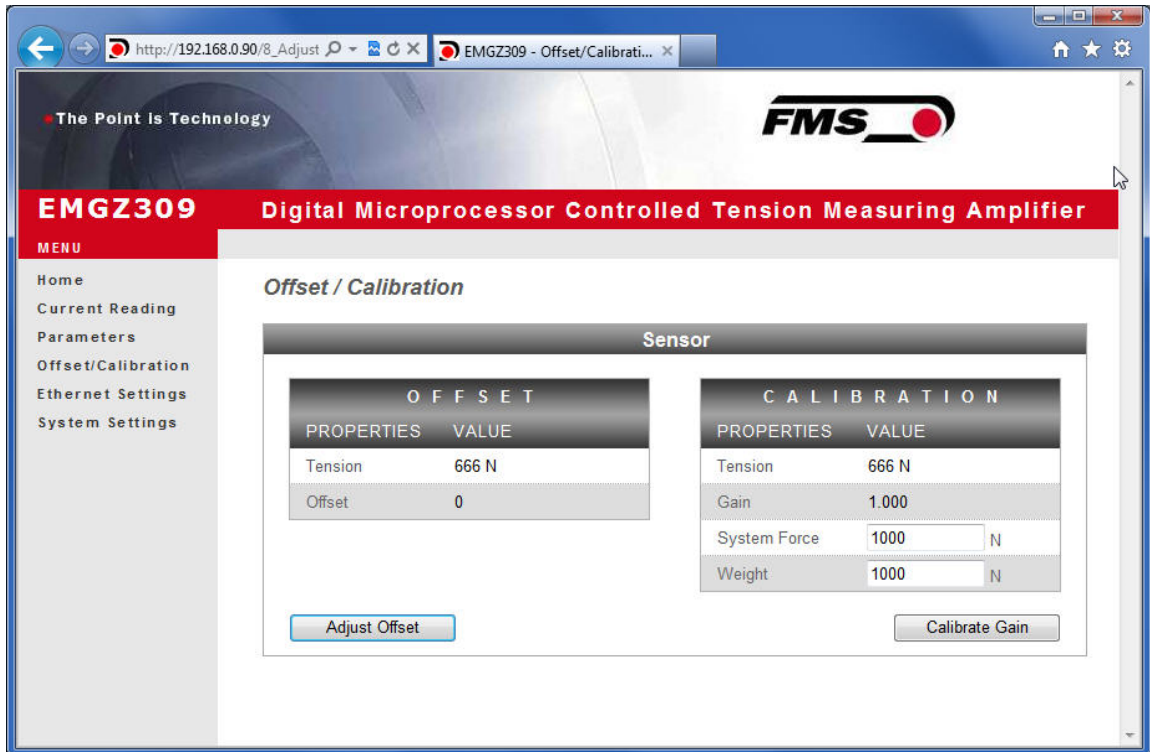
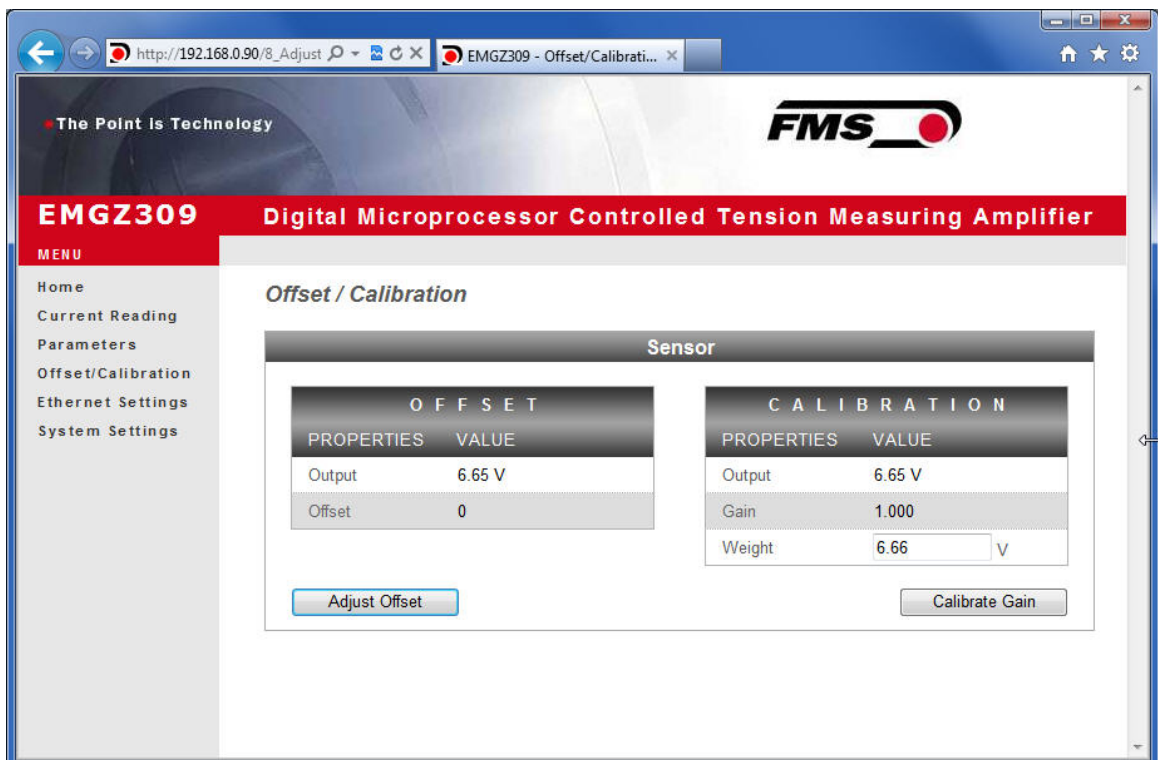

Fig.21: Parameter list for Device Mode Volt Gauge

Parameters-Volt



**Fig. 22: Offset compensation and calibration for Device Mode Force Gauge
Offset-Calibration-Force**



**Fig. 23: Offset compensation and calibration for Device Mode Volt Gauge
Offset-Calibration-Volt**

7.2 Offset Compensation via the Web Browser

1. Make sure the measuring roller is unloaded

2. In the page “Offset / Calibration” (Fig. 22 or 23) click on the box “Adjust Offset”
3. The values in the fields “Tension” or Output in the Offset-box will change to 0.
4. With that the Offset Compensation procedure finished.

7.3 Calibration via the Web Browser

A) For Device Mode Force Gauge

1. Load a rope with a defined weight corresponding to your calibration force on the roller. The roller configuration must correspond to the real configuration in the machine (wrap angle, distance of the rollers etc.).
2. The System Force [**SysForce**] determines the measuring capability of your measuring roller. E.g. if you use two 500 N sensors in your measuring roller, enter 1000N (see chapter 6.3 “Descriptions of Parameter”, [**SysForce**]).
3. Enter the [**SysForce**] in the corresponding box by overwriting the default or previous value.
4. Enter the force corresponding to your calibration weight in the box “Weight”
5. Click on the box “Calibrate Gain” to start the calibration procedure.
6. The Gain value will be calculated, indicated in the box “Gain” and stored in the parameter [**Gain**]. The calibration procedure has been completed successfully.

B) For Device Mode Volt Gauge

1. Load a rope with a defined weight corresponding to your calibration force on the roller. The roller configuration must correspond to the real configuration in the machine (wrap angle, distance of the rollers etc.).
2. Enter the force corresponding to your calibration weight in Volt (V) in the field “Weight”.

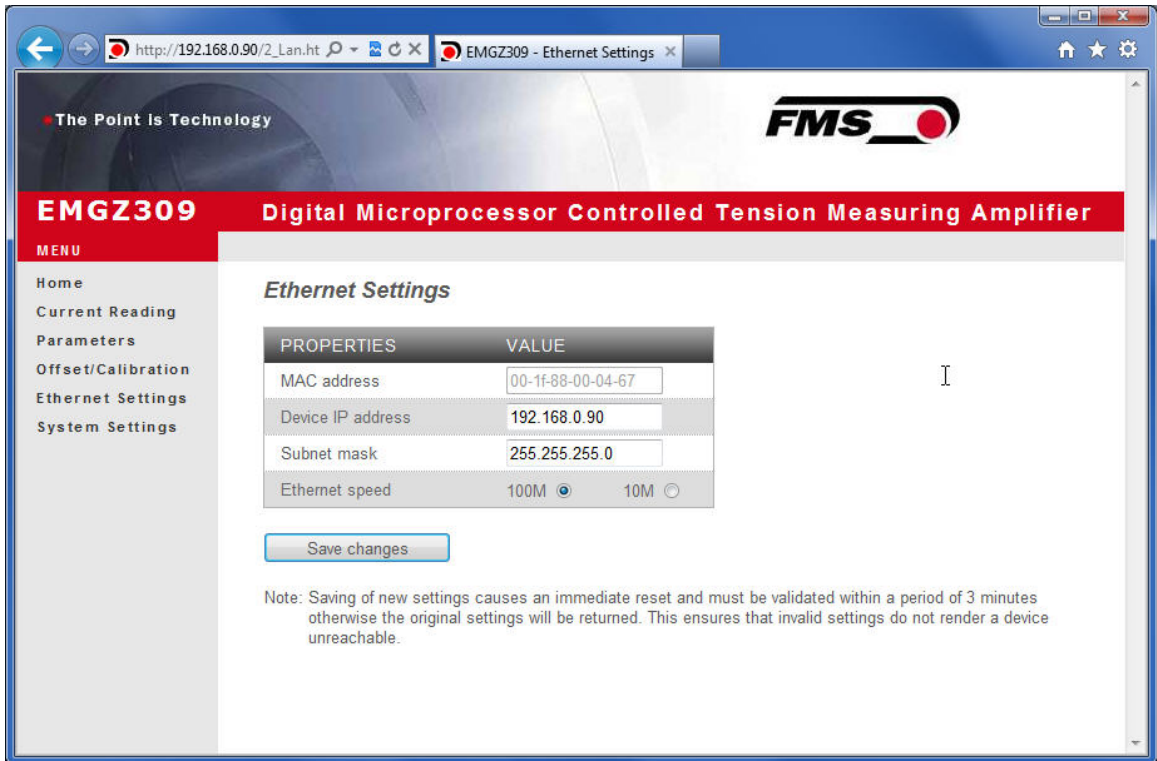

Fig. 24: Ethernet-Settings

Ethernet Settings

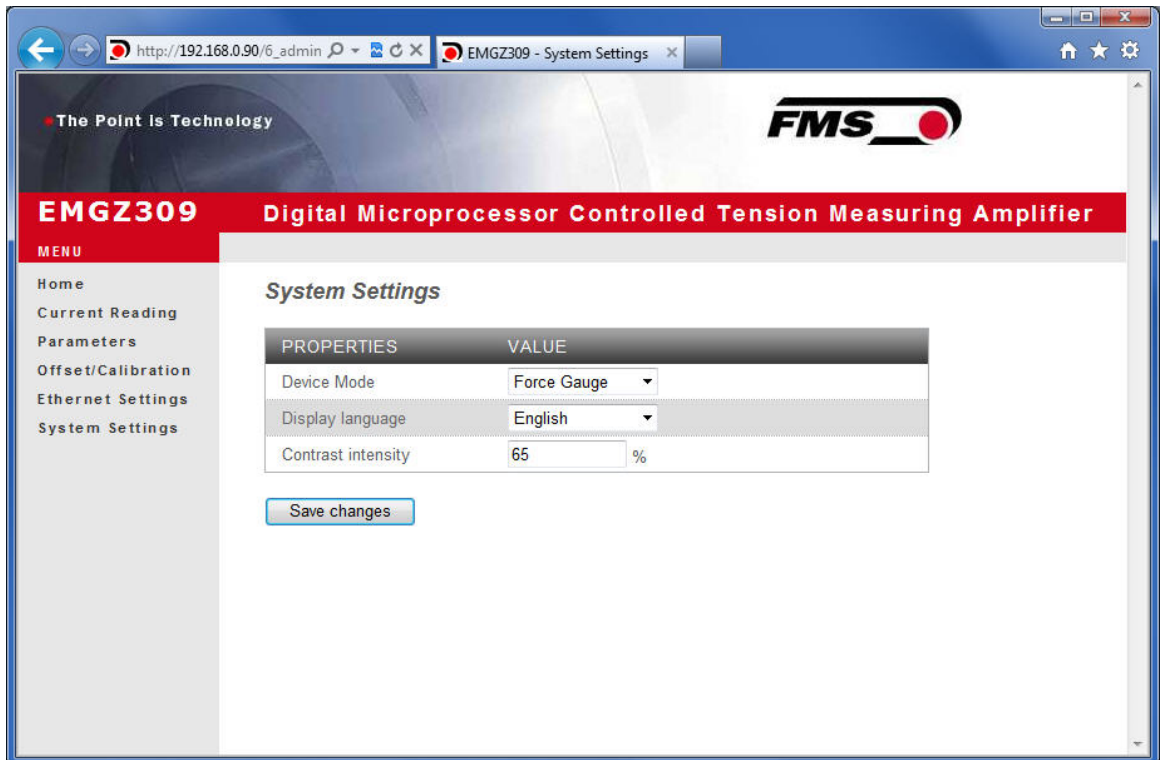

Fig. 25: System-Settings

System

7.4 Connecting the EMGZ309 Amplifier with a PC (Peer-to-Peer)

The parameter setting can also be carried out with a desktop or laptop computer directly connected to the EMGZ309. In this case, the PC is connected via a Peer-to-Peer connection to the amplifier. This chapter describes the procedure for setting up a computer to communicate with EMGZ309.

Setup for OS Window 7:

1. Connect PC and EMGZ309 with a “RJ-45 patch cable”
2. Power-up PC and EMGZ309
3. In order to recognize the EMGZ309 amplifier your PC must be configured with a static IP-address. Click on the Windows button (lower left-hand corner).
4. Click on Control Panel
5. Double click on Network ... Center.

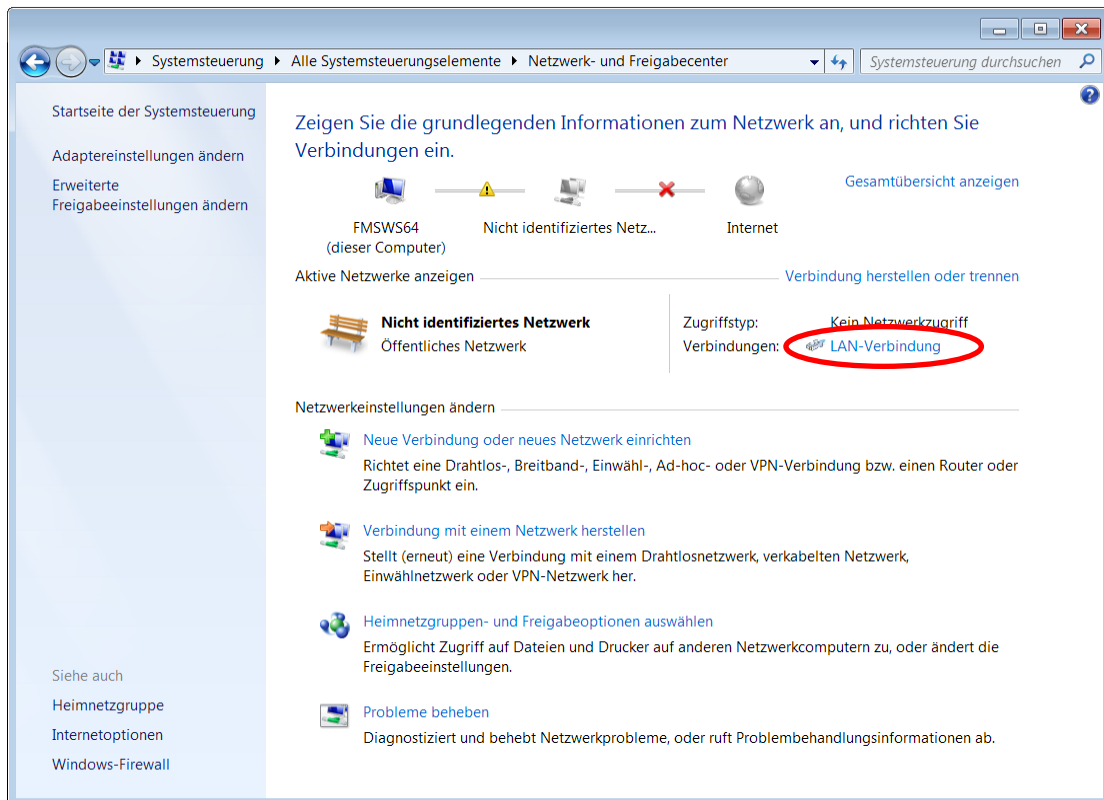

6. Double click on “Local Area Network”. The dialog box “Status of LAN connection” will open up.

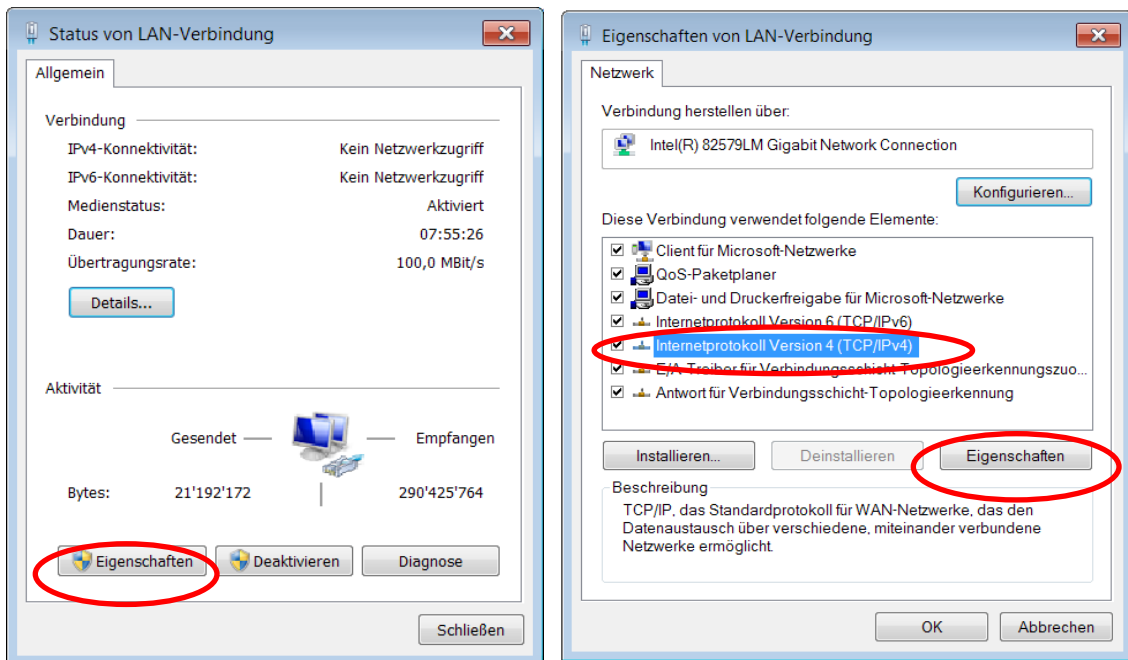

7. Click on Properties
8. On the next dialog box select the network adapter that is used for the connection. In our case "Internet protocol version 4 (TCP/IP)"
9. Click on Properties. The following dialog box "Internet protocol Version 4 (TCP/IPv4) Properties" will appear.

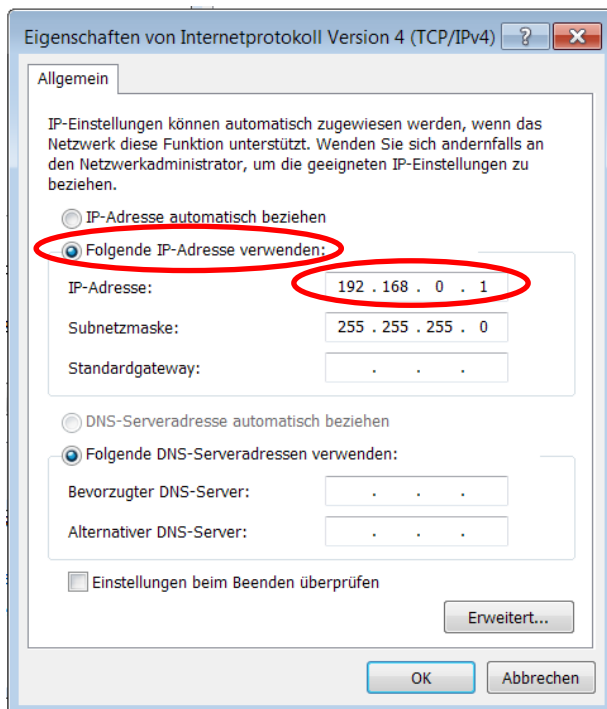

10. Select the radio button "Use the following IP address:"
11. Enter the IP address for the computer that could be 192.168.0.1
12. In the Subnet mask, enter 255 255 255 000, as shown above.
13. Click the "OK" button.
14. Close all windows

The computer is now ready to communicate with the EMGZ309 amplifier:

1. Open Microsoft Internet Explorer or Mizilla Firefox.
2. The default IP address for the EMGZ309 is **192.168.000.090** as long as it was not changed over the operating penal. Enter the IP address e.g. with <http://192.168.000.090> in the address bar and hit the Enter key. The screen "Device information" **Fig.17** will open up.
3. Then proceed as described in chapter 7.1 "Parameterization in a Network Using a Web Browser".
4. If a different IP address and subnet mask is configured at the EMGZ309 make sure that the computer is setup appropriate.
5. Once you return to your office, don't forget to reconfigure your PC to "Automatic assignment of the IP-address" (see last dialog box).

8 Dimensions

The EMGZ309 series is available in three different housing options. The mechanical dimensions can be seen in the following pages.

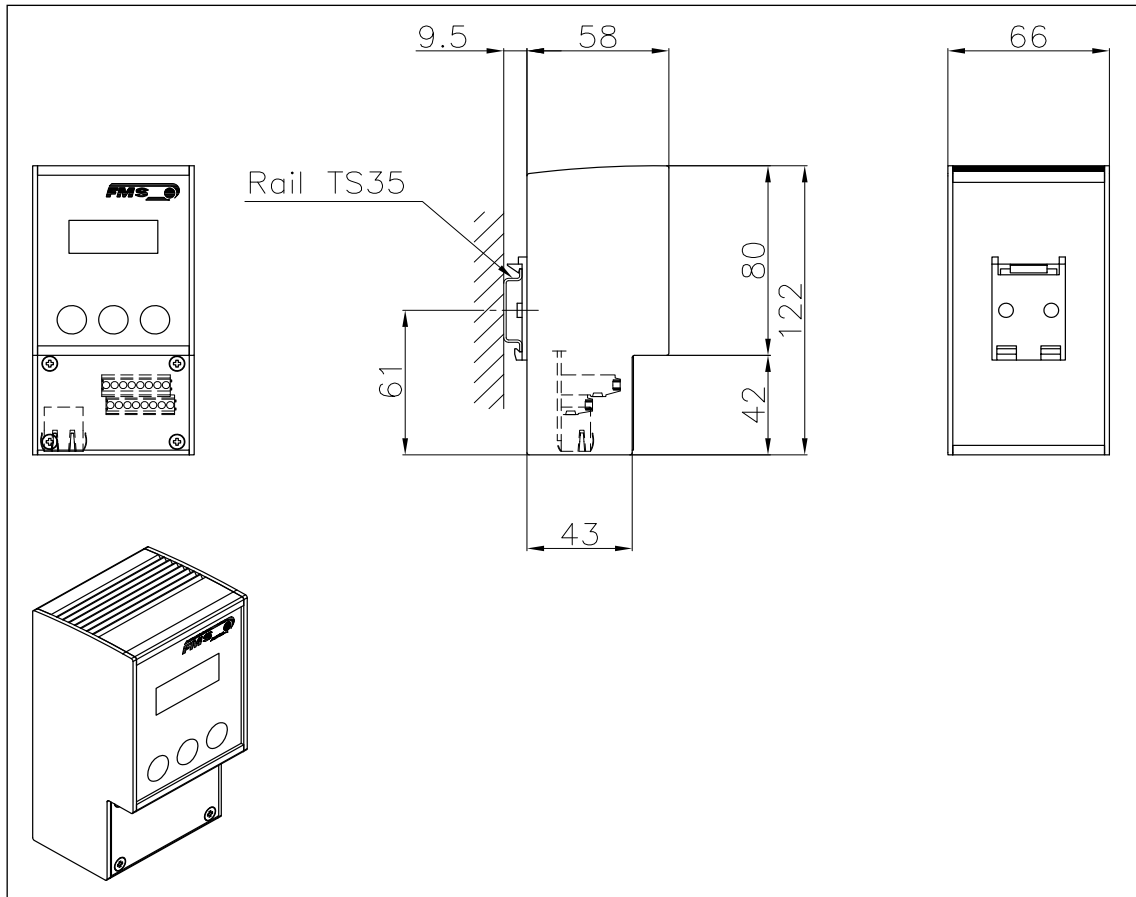

Fig. 26: Outline Drawing EMGZ309.R rail mount housing
Ethernet connection: RJ-45 connector

E309006e

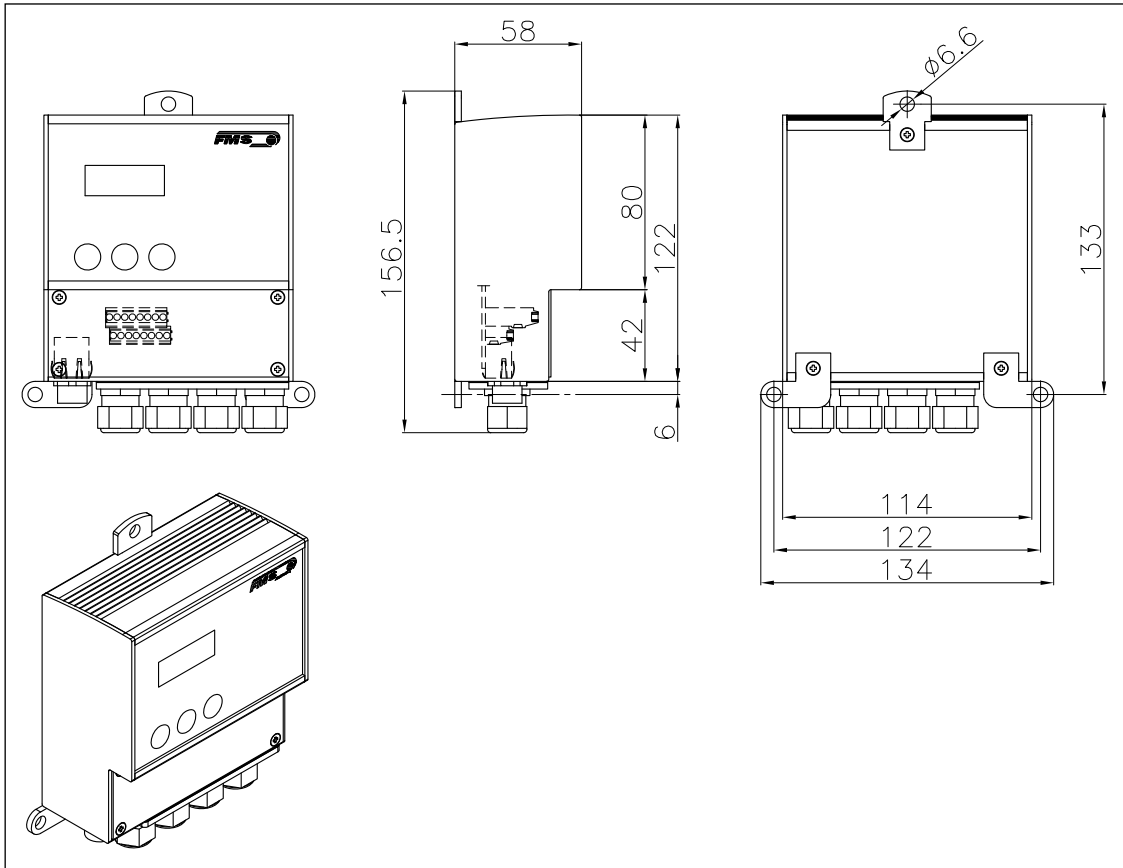

Fig. 27: Outline Drawing EMGZ309.W wall mount housing
Ethernet connection: M12 4-pole D-coded

E309004

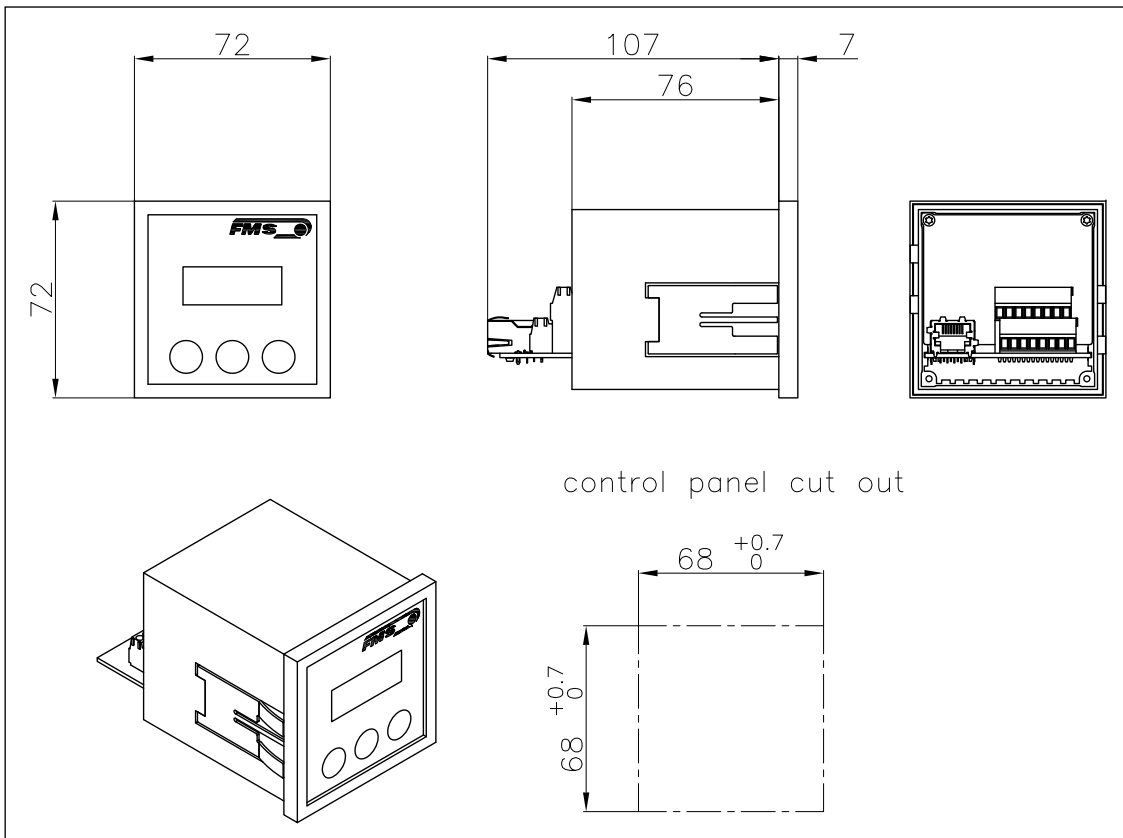

Fig. 28: Outline Drawing EMGZ309.S panel mount housing (RJ-45)

E309005e

9 Technical Specification

| | |
|-------------------------------------|--|
| Sensor excitation | 5VDC max. 60mA (high voltage stability) |
| Temperature drift offset | < 0.01% / K [0.006% / °F] |
| Linearity error | < 0.1% |
| Processor cycle time | 1ms |
| Operation /Parameter Setting | 3 keys and LCD 2x8 characters (size 8mm) |
| Interfaces | Ethernet via web browser (Ethernet Explorer 7 or higher) |
| Tension output | 0...10V min. 1.2kΩ |
| Current output | 0/4...20mA max. 500Ω |
| Power supply | 24VDC (18...36VDC) max. 0.3A |
| Power consumption | max. 6.0W |
| Temperature range | -10...+60 °C [14...140 °F] |
| Protection class | EMGZ309R and S: IP50; EMGZ309W: IP65 |
| Weight | EMGZ309R: 0.38kg [0.84 lbs]; EMGZ309S: 0.2kg [0.44 lbs]; EMGZ309W: 0.67kg [1.48 lbs] |



FMS Force Measuring Systems AG

Aspstrasse 6
8154 Oberglatt (Switzerland)
Tel. 0041 1 852 80 80
Fax 0041 1 850 60 06
info@fms-technology.com
www.fms-technology.com

FMS USA, Inc.

2155 Stonington Avenue Suite 119
Hoffman Estates., IL 60169 (USA)
Tel. +1 847 519 4400
Fax +1 847 519 4401
fmsusa@fms-technology.com

FMS (UK)

Aspstrasse 6
8154 Oberglatt (Switzerland)
Tel. +44 (0)1767 221 303
fmsuk@fms-technology.com

FMS (Italy)

Aspstrasse 6
8154 Oberglatt (Switzerland)
Tel. +39 02 39487035
fmsit@fms-technology.com